

**GOVERNMENT OF KHYBER PAKHTUNKHWA**  
**IRRIGATION DEPARTMENT**



**BIDDING DOCUMENTS**

**FOR**

**THE WORK**

- 1. Solarization of Existing Irrigation Tube Well in Tribal District [MA].ADP No. 2293 / 192017-190092 (2021-22).**
- 2. Need Assessment & Construction of New Solar Tube Wells & Solarization of Existing Tube Wells (AIP) ADP No: 2325/ 195196 during 2021-22)**

**Solarization of 12 Nos Tube Wells**

*ESTIMATED COST: As per NIT*

**IRRIGATION & HYDLE POWER DIVISION**  
**NORTH WAZIRISTAN TRIBAL DISTRICT**

Phone No: 0928-300508

**February 2021**

**INVITATION  
FOR BIDS**

## INVITING E-BIDDING

Irrigation Department Government of Khyber Pakhtunkhwa, Irrigation & Hydle Power Division Tribal District North Waziristan invites Technical and Financial (Electronic Bids) on the basis of single stage two envelop system from the Government Contractors/Firms enlisted with Irrigation Department Khyber Pakhtunkhwa who have renewed their enlistment and PEC license in relevant category for Solar (EE-11) for the year 2021-22 for the following works:

S.No	Name of Work/Sub Work.	Est:Cost (M)	Earnest Money	Required Category of PEC	Period of Completion.	Last date of submission & Time.	Opening Date & Time
(A)	<b>Solarization of Existing Irrigation Tube Well in Tribal District [MA]. ADP No. 2293 / 192017-190092 (2021-22).</b>						
1	Solarization of Existing Tube Well of Zahid Kassa Tehsil Mirali.	<b>5.000</b>	2% of Estimated Cost	EE-11 CE-04	As Per Work Order	24-02-2022 12:00 (P.M)	24-02-2022 12:30 (P.M)
2	Solarization of Existing Tube Well of Waheed Kassa Tehsil Mirali.	<b>5.000</b>	2% of Estimated Cost	EE-11 CE-04	-do-	-do-	-do-
3	Solarization of Existing Tube Well of Umer Faraz Kassa Tehsil Mirali.	<b>5.000</b>	2% of Estimated Cost	EE-11 CE-04	-do-	-do-	-do-
4	Solarization of Existing Tube Well of Numan Kassa Tehsil Dossali.	<b>5.000</b>	2% of Estimated Cost	EE-11 CE-04	-do-	-do-	-do-
(B)	<b>Need Assessment and Construction of New Solar Tube Wells &amp; Solarization of Existing Tube Wells (AIP). ADP No. 2325 / 195196 (2021-22).</b>						
1	Construction of New Solar Based Irrigation Tube Well at Wasim Rehman Kot Tabi Tol Khel Tehsil Miranshah NWTD. <b>(Solarization of Tube Well)</b>	<b>4.612</b>	2% of Estimated Cost	EE-11 CE-04	As Per Work Order	24-02-2022 12:00 (P.M)	24-02-2022 12:30 (P.M)
2	Construction of New Solar Based Irrigation Tube Well at Tarkha, Waheed Kot Haider Khel Village Tehsil Mirali NWTD. <b>(Solarization of Tube Well)</b>	<b>4.108</b>	2% of Estimated Cost	EE-11 CE-04	-do-	-do-	-do-
3	Construction of New Solar Based Irrigation Tube Well at Bada Khel Faqir Fazal Rahman Kot Tehsil Shewa NWTD. <b>(Solarization of Tube Well)</b>	<b>3.853</b>	2% of Estimated Cost	EE-11 CE-04	-do-	-do-	-do-
4	Construction of New Solar Based Irrigation Tube Well at Bakhtawar Kot Tehsil Shewa NWTD. <b>(Solarization of Tube Well)</b>	<b>4.187</b>	2% of Estimated Cost	EE-11 CE-04	-do-	-do-	-do-
5	Construction of New Solar Based Irrigation Tube Well at Hayat Ullah Kassa Shiratalla Tehsil Spinwam NWTD. <b>(Solarization of Tube Well)</b>	<b>4.015</b>	2% of Estimated Cost	EE-11 CE-04	-do-	-do-	-do-
6	Construction of New Solar Based Irrigation Tube Well at Kotka Kabir Khan Village Mullagan Tehsil Mirali NWTD. <b>(Solarization of Tube Well)</b>	<b>4.108</b>	2% of Estimated Cost	EE-11 CE-04	-do-	-do-	-do-

S.No	Name of Work/Sub Work.	Est:Cost (M)	Earnest Money	Required Category of PEC	Period of Completion.	Last date of submission & Time.	Opening Date & Time
7	Construction of New Solar Based Irrigation Tube Well at Kotka Arshad Khan Village Musaki Tehsil Mirali NWTD. <b>(Solarization of Tube Well)</b>	<b>4.108</b>	2% of Estimated Cost	EE-11 CE-04	-do-	-do-	-do-
8	Construction of New Solar Based Irrigation Tube Well at Shab Nawaz Rocha Bakka Khel Sub Division Wazir Bannu. <b>(Solarization of Tube Well)</b>	<b>5.831</b>	2% of Estimated Cost	EE-11 CE-04	-do-	-do-	-do-

### **TERMS AND CONDITIONS**

1. Technical Design should be based on Hydraulic Parameter of the scheme provided in the bidding documents and rates should be quoted accordingly in the financial bid. Technical bid will be opened on the date and time mentioned above by the bid opening committee in the office of the undersigned in the presence of bidders. Specification and design parameter of pumping machinery are given in the bidding documents.
2. Electronic bidding will be online through E-bidding system. Tender form and BOQ can be filled online and downloaded from the official website of Irrigation Department i.e. [www.irrigation.gkp.kp](http://www.irrigation.gkp.kp), moreover a complete set of bid solicitation documents may be obtained on submission of written application one-day prior to the opening date from office of the undersigned on cash payment nonrefundable fees of Rs. 2000/- otherwise bid submitted without these documents will be considered as non-responsive.
3. Electronic bidding shall be done on "above / below system" on BOQ / Engineer's estimate, based on the MRS 2020/2021. Only two digits after the decimal point shall be considered for evaluation purpose.
4. All bidders are required to have valid registration with Khyber Pakhtunkhwa Revenue Authority established under the Khyber Pakhtunkhwa Finance Act, 2018 (Khyber Pakhtunkhwa Act. XXI of 2013).
5. All the interested eligible bidders shall deposit their Call Deposit Receipt (CDR) in the name of Executive Engineer Irrigation & Hydrel Power Division NWTD five days prior to the closing date of bid submission.
6. The Executive Engineer shall only open the bid of those bidders whose security deposit has been credited to our official account before opening of bids.
7. In case, no security deposit is credited, the bid shall be considered non-responsive / rejected.

8. The bidder shall submit 2% bid security of the estimated cost in shape of call deposit along with the stamp duty in the name of Executive Engineer Irrigation & Hydel Power Division NWTD from schedule bank **through courier** before closing date and time.
9. The contactors quoting their bids up to a limit 15% below on Engineer's Estimate shall submit Bid Security to the extent of 2% of Engineer Estimate only.
10. In case the bidder quotes more than 15% below the Engineer Estimate and the bid is not accompanied by the Additional Security then the bid shall be considered as non-responsive and the 2<sup>nd</sup> lowest bidder and so on will be considered accordingly.
11. All Federal and Provincial taxes / duties shall be deducted from the bills of the contractors at prescribed rates as per Government Policy issued from time to time.
12. The bidders belonging to newly merged areas of tribal districts shall require to submit exemption certificate regarding Federal & Provincial Taxes / duties etc: from the concerned Federal / Provincial tax authorities on approval of their bids.
13. Any bidder who provided incorrect information shall stand disqualified as per KPPRA Act Section 29 (I) rule (43).
14. Successful bidders should sign the agreement with the Department within Twenty Eight (28) days after acceptance of bid.
15. Electronic bids will be displayed through online E-Bidding System after 30 minutes of closing time in the presence of bidders / their representative who choose to be present.
16. The procuring entity has the authority to reject any E-bid or all E-bids assigning valid reasons.
17. All the prevailing KPPRA rules / Act and other Govt. notifications will be applicable issued from time to time.
18. The defect liability period for 02 Years (all allied accessories) & Warranty for Solar Panel for 20 Years and shall be commence from the date of commissioning for each work.
19. Date of opening of financial bid will be announced after approval of Technical bid from the competent authority and will be communicated to all bidders accordingly.
20. Technical and Financial bids if received to the office of the undersigned unsealed will be rejected.

## **BID SOLICITATION DOCUMENTS**

### **FOR THE WORKS, TENDER DATED 24-02-2022**

<b>S.No</b>	<b>Name of Work / Sub Work.</b>	<b>E/Cost (M)</b>
<b>(A)</b>	<b>Solarization of Existing Irrigation Tube Well in Tribal District [MA]. ADP No. 2293 / 192017-190092 (2021-22).</b>	
1	Solarization of Existing Tube Well of Zahid Kassa Tehsil Mirali.	5.000
2	Solarization of Existing Tube Well of Waheed Kassa Tehsil Mirali.	5.000
3	Solarization of Existing Tube Well of Umer Faraz Kassa Tehsil Mirali.	5.000
4	Solarization of Existing Tube Well of Numan Kassa Tehsil Dossali.	5.000
<b>(A)</b>	<b>Need Assessment &amp; Construction of New Solar Tube Wells &amp; Solarization of Existing Tube Wells (AIP) ADP No. 2325/195196 during 2021-22)</b>	
1	Construction of New Solar Based Irrigation Tube Well at Wasim Rehman Kot Tabi Tol Khel Tehsil Miranshah NWT.D. (Solarization of Tube Well)	4.612
2	Construction of New Solar Based Irrigation Tube Well at Tarkha, Waheed Kot Haider Khel Village Tehsil Mirali NWT.D. (Solarization of Tube Well)	4.108
3	Construction of New Solar Based Irrigation Tube Well at Bada Khel Faqir Fazal Rahman Kot Tehsil Shewa NWT.D. (Solarization of Tube Well)	3.853
4	Construction of New Solar Based Irrigation Tube Well at Bakhtawar Kot Tehsil Shewa NWT.D. (Solarization of Tube Well)	4.187
5	Construction of New Solar Based Irrigation Tube Well at Hayat Ullah Kassa Shiratalla Tehsil Spinwam NWT.D. (Solarization of Tube Well)	4.015
6	Construction of New Solar Based Irrigation Tube Well at Kotka Kabir Khan Village Mullagan Tehsil Mirali NWT.D. (Solarization of Tube Well)	4.108
7	Construction of New Solar Based Irrigation Tube Well at Kotka Arshad Khan Village Musaki Tehsil Mirali NWT.D. (Solarization of Tube Well)	4.108
8	Construction of New Solar Based Irrigation Tube Well at Shab Nawaz Rocha Bakka Khel Sub Division Wazir Bannu. (Solarization of Tube Well)	5.831

Contractor: \_\_\_\_\_

For the Work: \_\_\_\_\_

**Appendix A to  
Instructions to Bidders**

**NAME OF ELIGIBLE COUNTRIES**

All countries of the World with whom Islamic Republic of Pakistan has commercial relations, in Construction Sector.

**Appendix B to  
Instructions to Bidders**

**EVIDENCE OF BIDDER'S CAPABILITY**







**Application Form A – 1****General Information**

*All individual firms and each partner of a joint venture applying for qualification are requested to complete the information in this form. Nationality information is also to be provided for foreign owners or applicants who are forming part of the Joint Ventures as required under the PEC Bye-Laws as a Partnership/Joint Venture.*

*Where the Applicant proposes to use named subcontractors for critical components of the works or for work contents in excess of 10 percent of the value of the whole works, the following information should also be supplied for the specialist subcontractor(s).*

1.	Name of Firm	
2.	Head Office Address	
3.	Telephone	Contact Person: Name: Title:
4.	Fax	
5.	Place of Incorporation/Registration	Year of Incorporation/Registration

<b>NATIONALITY OF OWNERS</b>		
	<b>NAME</b>	<b>NATIONALITY</b>
1.		
2.		
3.		
4.		
5.		

**Application Form A – 2****General Experience Record**

Name of Applicant or partner of a joint venture
---

*All individual firms and all partners of a joint venture are requested to complete the information in this form. The information supplied should be the annual turnover of the Applicant (or each member of a joint venture), in terms of the amounts billed to clients for each year for work in progress or completed over the past five years.*

*Use a separate sheet for each partner of a joint venture.*

<b>Annual Turnover</b>		
<b>Year</b>	<b>Turnover (in actual currency)</b>	<b>Equivalent Rupees in Millions</b>
1.		
2.		
3.		
4.		
5.		

**Application Form A - 3****Joint Venture Summary**

<b>Names of all Partners of a Joint Venture</b>	
1.	Lead Partner
2.	Partner
3.	Partner

*Total value of annual turnover, in terms of work billed to clients,*

<b>Annual Turnover Data (Equivalent in Pak Rupees, Millions)</b>						
<b>Partner</b>	<b>Form A-2 Page No.</b>	<b>Year 1</b>	<b>Year 2</b>	<b>Year 3</b>	<b>Year 4</b>	<b>Year 5</b>
1. Lead Partner						
2. Partner						
3. Partner						
<b>Total:</b>						

## **Application Form A – 4**

### **Particular Experience Record**

*Name of Applicant or partner of a joint venture*

*On a separate page, using the format of Application Form A-5, each applicant or partner of a Joint Venture is required to list all contracts of a value equivalent to Pak **Rupees 10 million** and above of a similar nature and complexity (Supply & Installation of Solar Based Pumping Machinery in any Public Work/NGOs) to the contract for which the Applicant wishes to qualify, undertaken during the last five years. The information is to be summarized, using Application Form A-5, for each contract completed or under execution by the Applicant or by each partner of a Joint Venture.*

*Where the Applicant proposes to use named subcontractor(s) for critical components of the works or for work contents in excess of 10 percent of the value of the whole works, the information in the afore-mentioned forms should also be supplied for each specialist subcontractor.*

**Application Form A – 5**  
**Details of Contracts of Similar Nature & Complexity**

*Name of Applicant or partner of a joint venture*

Use a separate sheet for each contract.

1.	Name of Contract
	Country
2.	Name of Employer
3.	Employer Address..... .....
4.	Nature of works and special features relevant to the contract for which the Applicant wishes to pre-qualify ..... ..... .. ..... .....
5.	Contract Role (Tick One)  (a) Sole Contractor                      (b) Sub- Contractor                      (c) Partner in a Joint Venture
6.	Value of the total contract (in specified currencies) at completion, or at date of award for current contract  Currency .....                      Currency .....                      Currency .....
7.	Equivalent in Pak/Rs.
8.	Date of Award
9.	Date of Completion
10.	Contract Duration (Years and Months)  _____ Years                      _____ Months
11.	Specified Requirements <sup>1</sup> ..... ..... ..... .....

<sup>1</sup>Insert any specific criteria required for particular operations, such as annual volume of earthmoving, underground excavation, or placing concrete etc.

**Application Form A – 6****Summary Sheet: Current Contract Commitments/Works in Progress**

<i>Name of Applicant or partner of a joint venture</i>
--

*Applicants and each partner to an application should provide information on their current commitments on all contracts that have been awarded, or for which a letter of intent or acceptance has been received, or for contracts approaching completion, but for which substantial Completion Certificate has yet to be issued.*

<b>Name of Contract</b>	<b>Value of Outstanding work (Equivalent Pak Rs. Millions)</b>	<b>Estimated Completion Date</b>
1.		
2.		
3.		
4.		
5.		
6.		



**Application Form A – 7**

**Personnel Capabilities**

<i>Name of Applicant</i>
--------------------------

*For specific positions essential to contract implementation, Applicants should provide the names of at least two candidates qualified to meet the specified requirements stated for each position. The data on their experience should be supplied on separate sheets using one Form for each candidate (Application Form A-8).*

1.	Title of Position
	Name of Prime Candidate
	Name of Alternate Candidate
2.	Title of Position
	Name of Prime Candidate
	Name of Alternate Candidate
3.	Title of Position
	Name of Prime Candidate
	Name of Alternate Candidate
4.	Title of Position
	Name of Prime Candidate
	Name of Alternate Candidate

**Application Form A – 8**

**Candidate Summary**

*Name of Applicant*

<b>Position</b>		<b>Candidate</b> [Tick appropriate one]  <input type="checkbox"/> Prime    • <input type="checkbox"/> Alternate
Candidate information	1. Name of Candidate	2. Date of Birth
	3. Professional Qualification	4. PEC Registration No.
Present employment	5. Name of employer	
	Address of employer	
	Telephone	Contact (manager/personnel officer)
	Fax	
	Job title of candidate	Years with present employer

*Summarize professional experience over the last 10 years, in reverse chronological order. Indicate particular technical and managerial experience relevant to the Project.*

Month/ Dates/Years		Company/Project/Position/Relevant technical and management experience
From	To	

## Application Form A - 9 Equipment Capabilities

*Name of Applicant*

*The Applicant shall provide adequate information to demonstrate clearly that he has the capability to meet the requirements for each and all items of equipment listed in the Evaluation Criteria 1.2 (v). A separate Form shall be prepared for each item of equipment listed or for alternative equipment proposed by the Applicant.*

<b>Item of Equipment</b>		
Equipment information	1. Name of manufacturer	2. Model and power rating
	3. Capacity	4. Year of manufacture
Current status	5. Current location	
	6. Details of current commitments	
Source	7. Indicate source of the equipment  <input type="checkbox"/> Owned    ·    Rented    ·    Leased	

*Omit the following information if it is owned by the Applicant or partner.*

Owner	8. Name of owner	
	9. Address of owner	
	Telephone	Contact name and title
	Fax	
Agreement	Details of rental/lease specific to the Project	

**Application Form A - 10**  
**Financial Capability**

***Name of Applicant or Partner of a Joint Venture***

Applicants, including each partner of a joint venture, should provide financial information to demonstrate that they meet the minimum requirements that the lead partner shall meet not less than 40 percent of all qualifying criteria and each of the partners shall meet not less than 25 percent of all the qualifying criteria given in Evaluation Criteria. All the above figures will be added together to arrive at JV's total capacity. Each applicant or partner of a joint venture must fill-in this form. If necessary, use separate sheets to provide complete banker information. A copy of the audited balance sheets should be attached.

<b>Banker</b>	Name of banker	
	Address of banker	
	Telephone	Contact name and title
	Fax	Telex

Summarize actual assets and liabilities in Pak Rupees (Equivalent at the current rate of exchange at the end of each year) for the previous five years, based upon known commitments, projected assets and liabilities in pak Rupees equivalent for the next two years.

Financial information in Pak Rs. or equivalent	Actual: previous five year					Projected next two years	
	1	2	3	4	5	6	7
1. Total assets							
2. Current assets							
3. Total liabilities							
4. Current liabilities							
5. Profits before taxes							
6. Profits after taxes							

Specific proposed sources of financing to meet the cash flow of the Project, net of current commitments

Source of financing	Amount (Pak Rs. or equivalent)
1.	
2.	
3.	
4.	

Attach audited financial statements for the last five years (for individual applicant or each partner of joint venture). Firms owned by individuals, and partnerships, may submit their balance sheets certified by a registered accountant, and supported by copies of tax returns, if audits are not required by the laws of their countries of origin in case of foreign firms.



## Check List

Ye s	N o	Check list
.	.	Valid PEC Certificate(s) in required category
.	.	Copy of valid dealer ship certificate
.	.	Application form (A-1), General Information
.	.	Application form (A-2), General Experience Record
.	.	Application form (A-3), Joint Venture Summary
.	.	Application form (A-4), Particular Experience (Record List of Solar based pumping machinery projects of similar nature and complexity completed in last five years and complexity in- hand.)
.	.	Application form (A-5), Detail of Contracts of Similar Nature and Complexity (Supply & Installation of Solar based pumping machinery)
.	.	Application form (A-6) Current Contract Commitments/Works in Progress
.	.	Application form (A-7), Personnel Capabilities
.	.	Application form (A-8) Candidate Summary (List of B.Sc. Engineers having relevant experience with their CVs and PEC Reg. No.& List of Associates Engineers (DAE) with their CVs having relevant experience )
.	.	Application form (A-9), Equipment capabilities
.	.	Application form (A-10), Financial Capability
.	.	Application form (A-11), Litigation History
.	.	Undertaking that all equipment listed in this document for qualification will be made available for the subject Project
.	.	Audited balance sheets for at least last three years and Bank statements
.	.	Undertaking that the Applicant has not been declared bankrupt
.	.	Original affidavit that the firm has not been black listed
.	.	Applicants legal status
.	.	Principal place of Business
.	.	Place of incorporation or registration
.	.	Certificate of registration with Income Tax & Sales Tax Department
.	.	Enlistment record with Government organizations and other agencies
.	.	Location of workshop facility, if any
.	.	Equipment's sole agencies represented by the Contractor
.	.	Written description of internal quality control program for specified works

## EVALUATION CRITERIA

### 1.1 Eligibility for Qualification

Keeping in view the complexity of the Project, eligibility of Applicants for qualification evaluation is as mentioned below:

Sr. No.	Description	Yes/No
1.	Registration with Pakistan Engineering Council (PEC) in relevant category with field of specialization EE-11 <b>(Specified for Solar Energy)</b>	If "YES" the applicant will be Eligible for further Evaluation for qualification (copy of valid PEC certificate shall be attached).
2.	Blacklisting from any Government/Semi-Government Agency/Department.	If "YES" the applicant will not be Eligible for further Evaluation for qualification. (Original Affidavit on Judicial Stamp Paper that the firm has not been black listed from any Government/ Semi Government Agency/ Department till date shall be provided).
3.	System Design	Valid System Design must be submitted in technical bid otherwise applicant will not be Eligible for further Evaluation.
4.	<ul style="list-style-type: none"> <li>i. Firm must have ISO 9001-2008 certificate quality management system</li> <li>ii. Warranty period for solar panel etc will be 20 years and Defect liability period of Electrical / Mechanical works will be 2 years.</li> <li>iii. Firm must have the average annual turnover for the last 5 years in Solar Pumping Machinery must equal to or more than engineer estimate, must be attached Sales Tax Returns, Income Tax Returns &amp; Financial Audited Balance Sheets &amp; figure must be correspond with each other.</li> </ul>	Attach Valid documents otherwise applicant will not be eligible for further evaluation

	<ul style="list-style-type: none"> <li>iv. Goods declaration/purchase documents (bill of entry) must be provided for each product (i.e Solar Panel, Pumps, Motors, Inverter &amp; Tracker Sleeve Drive).</li> <li>v. Performance curves at STC for both solar panel and pumping machinery should be provided for each work separately along with bidding documents</li> <li>vi. The PV modules offered should not be more than One (01) year old with respect to the date of manufacturing.</li> <li>vii. Brand name(s) of PV modules, the supplier intends to supply must be included in the technical proposal.</li> </ul>	
--	--	--

Keeping in view the complexity of the Project works, criteria for qualification has been evolved by considering the prevailing market trends as mentioned below:

Sr. No.	Category	Weightage/Marks
i.	General Capabilities	10
ii.	Financial Soundness	20
iii.	Experience Record	30
iv.	Personnel Capabilities	20
v.	Equipment Capabilities	20
Total:		100

Qualification will be carried out on the point scoring basis. Any applicant securing overall minimum score of 60 % as total will be considered as qualified.

An applicant may score below 60% in any one category provided it is not less than 50%.

Applicants having score of less than 60% in any two categories shall not be considered for further evaluation.



## Qualification Evaluation Criteria

### i) General Capabilities

a)	Copy of valid dealership (solar panels)	<b>04</b>	<ul style="list-style-type: none"> <li>No marks will be given if license is not attached and four (04) points will be added in case of valid certificate along with import/purchase documents.</li> </ul>
b)	Copy of valid dealership (Submersible Pumps)	<b>04</b>	<ul style="list-style-type: none"> <li>No marks will be given if license is not attached and four (04) points will be added in case of valid certificate along with import/purchase documents.</li> </ul>
c)	Copy of valid dealership (Inverter)	<b>02</b>	<ul style="list-style-type: none"> <li>No marks will be given if license is not attached and two (02) points will be added in case of valid certificate along with import/purchase documents.</li> </ul>
<b>Total Marks Allocated</b>		<b>10</b>	

### ii) Financial Soundness

Sr. No.	Description	Marks Assigned	Criteria for Marks Obtained
a)	Bank Certificate including Bank Credit Line (Evidence in Original from Guarantor Bank)	5	<p><b><u>Bank Certificate (2-Marks)</u></b></p> <ul style="list-style-type: none"> <li>2 Marks are given if Original Bank Certificate is provided.</li> </ul> <p><b><u>Bank Credit Line (3-Marks)</u></b></p> <ul style="list-style-type: none"> <li>2 Marks are given if the available bank credit line limit is equal to 50 Million.</li> <li>For limit less than 50 Million, use following weight-age: <math>2 \times (A/50)</math></li> <li>For the limit more than 50 million but less than 100 million use following weight-age:</li> </ul>

			$2 + (A/100)$  A = Available Bank Credit Line Limit  <ul style="list-style-type: none"> <li>• Full Marks are given in case of limit is 100 million or more.</li> </ul>
b)	Audited Balance Sheets for at least last three years	06	No marks will be given if Audited Balance Sheets are not attached. Two (2) points will be given for each year audited balance sheets,
c)	Working Capital in last 5 years	5	<ul style="list-style-type: none"> <li>• 3 Marks are given if the available average working capital for last three years is equal to 50 Million.</li> <li>• For the capital less than 50 million use following weight-age:   <math>3 \times (A/50)</math></li> <li>• For the capital more than 50 million but less than 100 million use following weight-age.   <math>3 + (A/100)</math>   A = Average working capital in last three years.</li> <li>• Full Marks are given in case of limit is 100 million or more.</li> </ul>
d)	Registration with income tax & sale tax department	4	No marks will be given if NTN & GST Registration certificate is not attached and 4 points will be added in case of valid certificates.
<b>Total Marks Allocated</b>			<b>20</b>

iii) **Experience Record**

Sr. No.	Description	Marks Assigned	Explanation for Marks Obtained
a)	Projects of similar nature and complexity 10 Million (Supply & Installation of Solar Based Pumping Machinery) completed in last five years in any Public Works Department/NGOs.	16	<ul style="list-style-type: none"> <li>• 8 Marks are given if the applicant has completed at least 5 projects of similar nature in last five years.</li> <li>• For less than 5 projects completed use the following weight age. <math>8 \times (A/5)</math></li> <li>• For more than 5 projects but less than 10 projects completed use the following weight age. <math>8 + (A/5) \times 4</math></li> </ul> <p>A = No of projects of similar nature completed in last five years</p> <ul style="list-style-type: none"> <li>• Full Marks are given in case of 10 projects or more.</li> </ul>
b)	Projects of similar nature and complexity 10 Million (Supply & Installation of Solar Based Pumping Machinery) in-hand in any Public Works Department/NGOs.	9	<ul style="list-style-type: none"> <li>• 4 Marks are given if the applicant has completed at least 5 projects of similar nature in last five years.</li> <li>• For less than 5 projects completed use the following weight age. <math>4 \times (A/5)</math></li> <li>• For more than 5 projects but less than 10 projects completed use the following weight age. <math>4 + (A/10) \times 4</math></li> </ul> <p>A = No of projects of similar nature completed in last five years</p> <p>Full Marks are given in case of 10 projects or more.</p>

c)	Enlistment record with Government Organizations & other agencies	5	<ul style="list-style-type: none"> <li>1 Mark for each enlistment up to maximum of five enlistments.</li> </ul>
<b>Total Marks Allocated</b>			<b>30</b>

iv) **Personnel Capabilities**

Sr. No.	Description	Marks Assigned	Explanation for Marks Obtained
i)	B.Sc. Engineers registered with Pakistan Engineering Council (PEC)	14	<p><b><u>Experience (6-Marks)</u></b></p> <ul style="list-style-type: none"> <li>6 Marks will be given if the individual relevant experience of at least 1 numbers of B.Sc. Engineer Electrical/Electronics/Mechanical (professional) is equal to 15 years or above.</li> </ul> <p><b><u>Strength of Engineers (8 Marks)</u></b></p> <ul style="list-style-type: none"> <li>4 Marks will be given if the total no. of Engineers registered with PEC is 3.</li> <li>8 Marks will be given if the total no. of engineers registered with PEC is 5 or above.</li> </ul>
ii)	Associates Engineers (DAE)	6	<p><b><u>Experience (4-Marks)</u></b></p> <ul style="list-style-type: none"> <li>4 Marks will be given if the individual relevant experience of at least 1 number of Associates Engineers Electrical/Mechanical (DAE) is equal to 8 years or above.</li> </ul> <p><b><u>Strength of Associate Engineers (2 Marks)</u></b></p> <ul style="list-style-type: none"> <li>2 Marks will be given if the total no. of Associate Engineers (DAE) are 3 or above.</li> </ul>
<b>Total Marks Allocated</b>			<b>20</b>

**v) Equipment Capabilities**

<b>Sr. No.</b>	<b>Description</b>	<b>Marks Assigned</b>	<b>Explanation for Marks Obtained</b>
a)	1. Test Bed for verification / testing of Solar pumps along with all accessories as per ISO-9906 in company premises. (Firm must have Third Party Certification regarding Test Bed arrangements).	8	13 Marks for complete setup are given. (Attached Third Party Certificate)
b)	Workshop facilities. Attach layout sketch of workshop.	4	Full marks will be given if workshop in KPK otherwise 02 Marks will be given. No marks will be given if Contractor has no workshop facilities.
c)	Equipment sole agencies represented by the Contractor	2	1 mark for each agency Upto maximum 2 points
d)	Flowmeter	2	Valid Documents and pictures along with serial number must be provided.
e)	Water level Meter	2	Valid Documents and pictures along with serial number must be provided.
f)	PV Analyzer	2	Valid Documents and pictures along with serial number must be provided.
<b>Total Marks Allocated</b>			<b>20</b>

**Appendix C to  
Instructions to Bidders**

**Domestic Goods (Value added in Pakistan)**

NOT USED



# Bill of Quantity

**Name of Scheme:** Solarization of Existing Irrigation Tube Well in Tribal District [MA].  
ADP No. 2293 / 192017-190092 (2021-22).

**Sub Scheme:** Solarization of Existing Tube Well of Zahid Kassa Tehsil Mirali.

S.No	S. Item Code MRS 2021	Items Description	Unit	Unit Rate (Rs.) including installation price (A)	Quantity (B)	Total Amount (Rs.) (AXB)
1	26-01-d-01	Supply & Erection of Solar PV module (Solar Panel) Mono-crystalline A-Grade (Per Watt) (as per approved specification)	Watt	73.80	22245	1,641,681
2	26-01-b-02	Supply & Erection of PVC flexible pipe "1.5 i/d.	M	363.34	52	18,894
3	26-01-g-04	Supply & Erection 1X10 sq. mm flexible copper cable	M	355.69	85	30,234
4	26-01-h-01	Supply & Erection MC4 connector (TUV approved)	Pair	274.57	15	4,119
5	26-01-i-03-b	Supply and Erection of GRID TIE INVERTER(ON-Grid Inverter) (10-20 KW)	Watt	24.44	22245	543,668
6	26-01-m-01	Supply & Erection of hot dipped (80 microns Average) galvanised steel of minimum thickness of 12 SWG/2.64 mm channel/pipe or 8 SWG/4.06 mm angle.	Watt	22.19	22245	493,617
7	26-01-n-02	Supply & Erection of 1x1 ft 4 mm Copper Earthing Plate	Watt	3.92	22245	87,200
8	26-01-n-03	Supply & Erection of stainless steel nuts & bolts	Watt	3.92	22245	87,200
9	24-50-a-03	Supply & Installation, Testing and Commissioning of Submersible Pump (ISO-9906 certified) coupled with Submersible Rewindable Electric Motor with AC winding and all accessories like MCU (equipped with UV/OV, dry run protection device, surge protection, phase reverse indicator) complete in all accessories i/c NRV, Pressure Gauge, Sluice Valve with appropriate Head and Discharge <b>25</b> HPs	Set	462608	1	462,608
10	24-50-c-02	Supply & Installation of Submersible Plate Cable made of 99.9% copper, quoted with double PVC as per DSS Standard 3/16 mm2	M	889.35	110	97,829
11	24-56-b	Supply & Fixing MS Column Pipe with flanges for Submersible Pump 3" (75 mm) Nominal Pipe Size 3/16" thick, 10' length	M	2391.11	85	203,244



12	24-30-c-06	Providing, Laying, Cutting, Jointing, Testing and Disinfecting high density polyethylene pipe HDPE ISO-4427 in trenches, complete in all respects except excavation. (63 mm dia) PN-12.5	M	377.38	70	26,417
13	24-30-c-03	Providing, Laying, Cutting, Jointing, Testing and Disinfecting high density polyethylene pipe HDPE ISO-4427 in trenches, complete in all respects except excavation. (32 mm dia) PN-12.5	M	126.04	90	11,344
14	26-01-f-06	Supply and Erection of 12 V Lithium LiFeP04 battery per KWhr	M	69801.3	14	977,218
14	03-25-c	Excavation in foundation of building, bridges etc: complete in hard soil or soft murum	M <sup>3</sup>	309.92	11.150	3456
15	06-05-f	Plain Cement Concrete (PCC) including placing, compacting, finishing and curing (Ratio 1:2:4).	M <sup>3</sup>	8587.41	9.557	82070
<b>Total</b>						<b>4,770,797</b>
<b>Add Cost Factor 1.05</b>						<b>5,009,337</b>
<b>Say Million Rs.</b>						<b>5.000</b>
Note: Following information is to be provided by the bidder otherwise bid shall be declared as non-responsive (must be duly supported by evidence of exemption).						
Amount exempted from Federal GST (PKR):						
Amount chargeable to 17% Federal (FBR) sales tax on goods (PKR):						
Federal (FBR) sales tax on goods @ 17% (PKR):						
Amount chargeable to _____% Provincial (KPPRA) sales tax on services (PKR):						
Provincial (KPPRA) sales tax on services @ _____ % (PKR):						

**Note:-**

**Any other item of work crop out during execution will be paid on M.R.S 2021. The Quantities are liable to be increased or decreased during execution.**

Contractor Premium S.I \_\_\_\_\_ % Above /Below

Contractor Premium N.S.I \_\_\_\_\_ % Above/ Below

**Contractor Signature** \_\_\_\_\_

**Sub Engineer,**

**Sub Divisional Officer  
Irrigation & Hydle Division  
Tribal District North Waziristan**

# Bill of Quantity

**Name of Scheme:** Solarization of Existing Irrigation Tube Well in Tribal District [MA].  
ADP No. 2293 / 192017-190092 (2021-22).

**Sub Scheme:** Solarization of Existing Tube Well of Waheed Kassa Tehsil Mirali.

S.No	S. Item Code MRS 2021	Items Description	Unit	Unit Rate (Rs.) including installation price (A)	Quantity (B)	Total Amount (Rs.) (AXB)
1	26-01-d-01	Supply & Erection of Solar PV module (Solar Panel) Mono-crystalline A-Grade (Per Watt) (as per approved specification)	Watt	73.80	22238	1,641,164
2	26-01-b-02	Supply & Erection of PVC flexible pipe "1.5 i/d.	M	363.34	52	18,894
3	26-01-g-04	Supply & Erection 1X10 sq. mm flexible copper cable	M	355.69	85	30,234
4	26-01-h-01	Supply & Erection MC4 connector (TUV approved)	Pair	274.57	15	4,119
5	26-01-i-03-b	Supply and Erection of GRID TIE INVERTER(ON-Grid Inverter) (10-20 KW)	Watt	24.44	22238	543,497
6	26-01-m-01	Supply & Erection of hot dipped (80 microns Average) galvanised steel of minimum thickness of 12 SWG/2.64 mm channel/pipe or 8 SWG/4.06 mm angle.	Watt	22.19	22238	493,461
7	26-01-n-02	Supply & Erection of 1x1 ft 4 mm Copper Earthing Plate	Watt	3.92	22238	87,173
8	26-01-n-03	Supply & Erection of stainless steel nuts & bolts	Watt	3.92	22238	87,173
9	24-50-a-03	Supply & Installation, Testing and Commissioning of Submersible Pump (ISO-9906 certified) coupled with Submersible Rewindable Electric Motor with AC winding and all accessories like MCU (equipped with UV/OV, dry run protection device, surge protection, phase reverse indicator) complete in all accessories i/c NRV, Pressure Gauge, Sluice Valve with appropriate Head and Discharge <b>25</b> HPs	Set	462608	1	462,608
10	24-50-c-02	Supply & Installation of Submersible Plate Cable made of 99.9% copper, quoted with double PVC as per DSS Standard 3/16 mm2	M	889.35	100	88,935
11	24-56-b	Supply & Fixing MS Column Pipe with flanges for Submersible Pump 3" (75 mm) Nominal Pipe Size 3/16" thick, 10' length	M	2391.11	85	203,244

12	24-30-c-06	Providing, Laying, Cutting, Jointing, Testing and Disinfecting high density polyethylene pipe HDPE ISO-4427 in trenches, complete in all respects except excavation. (63 mm dia) PN-12.5	M	377.38	70	26,417
13	24-30-c-03	Providing, Laying, Cutting, Jointing, Testing and Disinfecting high density polyethylene pipe HDPE ISO-4427 in trenches, complete in all respects except excavation. (32 mm dia) PN-12.5	M	126.04	100	12,604
14	26-01-f-06	Supply and Erection of 12 V Lithium LiFeP04 battery per KWhr	M	69801.3	14	977,218
14	03-25-c	Excavation in foundation of building, bridges etc: complete in hard soil or soft murum	M <sup>3</sup>	309.92	11.150	3456
15	06-05-f	Plain Cement Concrete (PCC) including placing, compacting, finishing and curing (Ratio 1:2:4).	M <sup>3</sup>	8587.41	9.557	82070
<b>Total</b>						<b>4,762,266</b>
<b>Add Cost Factor 1.05</b>						<b>5,000,379</b>
<b>Say Million Rs.</b>						<b>5.000</b>
Note: Following information is to be provided by the bidder otherwise bid shall be declared as non-responsive (must be duly supported by evidence of exemption).						
Amount exempted from Federal GST (PKR):						
Amount chargeable to 17% Federal (FBR) sales tax on goods (PKR):						
Federal (FBR) sales tax on goods @ 17% (PKR):						
Amount chargeable to _____% Provincial (KPPRA) sales tax on services (PKR):						
Provincial (KPPRA) sales tax on services @ _____ % (PKR):						

**Note:-**

**Any other item of work crop out during execution will be paid on M.R.S 2021. The Quantities are liable to be increased or decreased during execution.**

Contractor Premium S.I \_\_\_\_\_ % Above /Below

Contractor Premium N.S.I \_\_\_\_\_ % Above/ Below

**Contractor Signature** \_\_\_\_\_

**Sub Engineer,**

**Sub Divisional Officer  
Irrigation & Hydle Division  
Tribal District North Waziristan**

# Bill of Quantity

**Name of Scheme:** Solarization of Existing Irrigation Tube Well in Tribal District [MA].  
ADP No. 2293 / 192017-190092 (2021-22).

**Sub Scheme:** Solarization of Existing Tube Well of Umer Faraz Kassa Tehsil Mirali.

S.No	S. Item Code MRS 2021	Items Description	Unit	Unit Rate (Rs.) including installation price (A)	Quantity (B)	Total Amount (Rs.) (AXB)
1	26-01-d-01	Supply & Erection of Solar PV module (Solar Panel) Mono-crystalline A-Grade (Per Watt) (as per approved specification)	Watt	73.80	22230	1,640,574
2	26-01-b-02	Supply & Erection of PVC flexible pipe "1.5 i/d.	M	363.34	52	18,894
3	26-01-g-04	Supply & Erection 1X10 sq. mm flexible copper cable	M	355.69	85	30,234
4	26-01-h-01	Supply & Erection MC4 connector (TUV approved)	Pair	274.57	15	4,119
5	26-01-i-03-b	Supply and Erection of GRID TIE INVERTER(ON-Grid Inverter) (10-20 KW)	Watt	24.44	22230	543,301
6	26-01-m-01	Supply & Erection of hot dipped (80 microns Average) galvanised steel of minimum thickness of 12 SWG/2.64 mm channel/pipe or 8 SWG/4.06 mm angle.	Watt	22.19	22230	493,284
7	26-01-n-02	Supply & Erection of 1x1 ft 4 mm Copper Earthing Plate	Watt	3.92	22230	87,142
8	26-01-n-03	Supply & Erection of stainless steel nuts & bolts	Watt	3.92	22230	87,142
9	24-50-a-03	Supply & Installation, Testing and Commissioning of Submersible Pump (ISO-9906 certified) coupled with Submersible Rewindable Electric Motor with AC winding and all accessories like MCU (equiped with UV/OV, dry run protection device, surge protection, phase reverse indicator) complete in all accessories i/c NRV, Pressure Gauge, Sluice Valve with appropriate Head and Discharge <b>25</b> HPs	Set	462608	1	462,608
10	24-50-c-02	Supply & Installation of Submersible Plate Cable made of 99.9% copper, quoted with doule PVC as per DSS Standard 3/16 mm2	M	889.35	100	88,935
11	24-56-b	Supply & Fixing MS Column Pipe with flunges for Submersible Pump 3" (75 mm) Nominal Pipe Size 3/16" thick, 10' length	M	2391.11	85	203,244

12	24-30-c-06	Providing, Laying, Cutting, Jointing, Testing and Disinfecting high density polyethylene pipe HDPE ISO-4427 in trenches, complete in all respects except excavation. (63 mm dia) PN-12.5	M	377.38	70	26,417
13	24-30-c-03	Providing, Laying, Cutting, Jointing, Testing and Disinfecting high density polyethylene pipe HDPE ISO-4427 in trenches, complete in all respects except excavation. (32 mm dia) PN-12.5	M	126.04	105	13,234
14	26-01-f-06	Supply and Erection of 12 V Lithium LiFeP04 battery per KWhr	M	69801.3	14	977,218
14	03-25-c	Excavation in foundation of building, bridges etc: complete in hard soil or soft murum	M <sup>3</sup>	309.92	11.150	3456
15	06-05-f	Plain Cement Concrete (PCC) including placing, compacting, finishing and curing (Ratio 1:2:4).	M <sup>3</sup>	8587.41	9.557	82070
<b>Total</b>						<b>4,761,870</b>
<b>Add Cost Factor 1.05</b>						<b>4,999,963</b>
<b>Say Million Rs.</b>						<b>5.000</b>
Note: Following information is to be provided by the bidder otherwise bid shall be declared as non-responsive (must be duly supported by evidence of exemption).						
Amount exempted from Federal GST (PKR):						
Amount chargeable to 17% Federal (FBR) sales tax on goods (PKR):						
Federal (FBR) sales tax on goods @ 17% (PKR):						
Amount chargeable to _____% Provincial (KPPRA) sales tax on services (PKR):						
Provincial (KPPRA) sales tax on services @ _____ % (PKR):						

**Note:-**

**Any other item of work crop out during execution will be paid on M.R.S 2021. The Quantities are liable to be increased or decreased during execution.**

Contractor Premium S.I \_\_\_\_\_ % Above /Below

Contractor Premium N.S.I \_\_\_\_\_ % Above/ Below

**Contractor Signature** \_\_\_\_\_

**Sub Engineer,**

**Sub Divisional Officer  
Irrigation & Hydle Division  
Tribal District North Waziristan**

# Bill of Quantity

**Name of Scheme:** Solarization of Existing Irrigation Tube Well in Tribal District [MA].  
ADP No. 2293 / 192017-190092 (2021-22).

**Sub Scheme:** Solarization of Existing Tube Well of Numan Kassa Tehsil Dossali.

S.No	S. Item Code MRS 2021	Items Description	Unit	Unit Rate (Rs.) including installation price (A)	Quantity (B)	Total Amount (Rs.) (AXB)
1	26-01-d-01	Supply & Erection of Solar PV module (Solar Panel) Mono-crystalline A-Grade (Per Watt) (as per approved specification)	Watt	73.80	21535	1,589,283
2	26-01-b-02	Supply & Erection of PVC flexible pipe "1.5 i/d.	M	363.34	55	19,984
3	26-01-g-04	Supply & Erection 1X10 sq. mm flexible copper cable	M	355.69	85	30,234
4	26-01-h-01	Supply & Erection MC4 connector (TUV approved)	Pair	274.57	15	4,119
5	26-01-i-03-b	Supply and Erection of GRID TIE INVERTER(ON-Grid Inverter) (10-20 KW)	Watt	24.44	21535	526,315
6	26-01-m-01	Supply & Erection of hot dipped (80 microns Average) galvanised steel of minimum thickness of 12 SWG/2.64 mm channel/pipe or 8 SWG/4.06 mm angle.	Watt	22.19	21535	477,862
7	26-01-n-02	Supply & Erection of 1x1 ft 4 mm Copper Earthing Plate	Watt	3.92	21535	84,417
8	26-01-n-03	Supply & Erection of stainless steel nuts & bolts	Watt	3.92	21535	84,417
9	24-50-a-03	Supply & Installation, Testing and Commissioning of Submersible Pump (ISO-9906 certified) coupled with Submersible Rewindable Electric Motor with AC winding and all accessories like MCU (equiped with UV/OV, dry run protection device, surge protection, phase reverse indicator) complete in all accessories i/c NRV, Pressure Gauge, Sluice Valve with appropriate Head and Discharge <b>25</b> HPs	Set	462608	1	462,608
10	24-50-c-02	Supply & Installation of Submersible Plate Cable made of 99.9% copper, quoted with doule PVC as per DSS Standard 3/16 mm2	M	889.35	100	88,935
11	24-56-b	Supply & Fixing MS Column Pipe with flunges for Submersible Pump 3" (75 mm) Nominal Pipe Size 3/16" thick, 10' length	M	2391.11	85	203,244

12	24-30-c-06	Providing, Laying, Cutting, Jointing, Testing and Disinfecting high density polyethylene pipe HDPE ISO-4427 in trenches, complete in all respects except excavation. (63 mm dia) PN-12.5	M	377.38	70	26,417
13	24-30-c-03	Providing, Laying, Cutting, Jointing, Testing and Disinfecting high density polyethylene pipe HDPE ISO-4427 in trenches, complete in all respects except excavation. (32 mm dia) PN-12.5	M	126.04	95	11,974
14	26-01-f-06	Supply and Erection of 12 V Lithium LiFeP04 battery per KWhr	M	69801.3	14	977,218
14	03-25-c	Excavation in foundation of building, bridges etc: complete in hard soil or soft murum	M <sup>3</sup>	309.92	11.150	3456
15	06-05-f	Plain Cement Concrete (PCC) including placing, compacting, finishing and curing (Ratio 1:2:4).	M <sup>3</sup>	8587.41	9.557	82070
<b>Total</b>						<b>4,672,552</b>
<b>Add Cost Factor 1.07</b>						<b>4,999,630</b>
<b>Say Million Rs.</b>						<b>5.000</b>
Note: Following information is to be provided by the bidder otherwise bid shall be declared as non-responsive (must be duly supported by evidence of exemption).						
Amount exempted from Federal GST (PKR):						
Amount chargeable to 17% Federal (FBR) sales tax on goods (PKR):						
Federal (FBR) sales tax on goods @ 17% (PKR):						
Amount chargeable to _____% Provincial (KPPRA) sales tax on services (PKR):						
Provincial (KPPRA) sales tax on services @ _____ % (PKR):						

**Note:-**

**Any other item of work crop out during execution will be paid on M.R.S 2021. The Quantities are liable to be increased or decreased during execution.**

Contractor Premium S.I \_\_\_\_\_ % Above /Below

Contractor Premium N.S.I \_\_\_\_\_ % Above/ Below

**Contractor Signature** \_\_\_\_\_

**Sub Engineer,**

**Sub Divisional Officer  
Irrigation & Hydle Division  
Tribal District North Waziristan**

# Bill of Quantity

**Name of Scheme:** Need Assessment and Construction of New Solar Tube Wells & Solarization of Existing Tube Wells (AIP). ADP No. 2325 / 195196 (2021-22).

**Sub Scheme:** Construction of New Solar Based Irrigation Tube Well at Wasim Rehman Kot Tabi Tol Khel Tehsil Miranshah NWT.D. (Solarization of Tube Well)

S.No	S. Item Code MRS 2020	Items Description	Unit	Unit Rate (Rs.) including installation price (A)	Quantity (B)	Total Amount (Rs.) (AXB)
1	26-01-d-01	Supply & Erection of Solar PV module (Solar Panel) Mono-crystalline A-Grade (Per Watt) (as per approved specification)	Watt	72.58	27473	1,993,990
2	26-01-b-02	Supply & Erection of PVC flexible pipe "1.5 i/d.	M	357.37	43	15,367
3	26-01-g-04	Supply & Erection 1X10 sq. mm flexible copper cable	M	349.84	75	26,238
4	26-01-h-01	Supply & Erection MC4 connector (TUV approved)	Pair	270.07	15	4,051
5	26-01-i-03-b	Supply and Erection of GRID TIE INVERTER(ON-Grid Inverter) (10-20 KW)	Watt	24.04	27473	660,451
6	26-01-m-01	Supply & Erection of hot dipped (80 microns Average) galvanised steel of minimum thickness of 12 SWG/2.64 mm channel/pipe or 8 SWG/4.06 mm angle.	Watt	21.82	27473	599,461
7	26-01-n-02	Supply & Erection of 1x1 ft 4 mm Copper Earthing Plate	Watt	3.86	27473	106,046
8	26-01-n-03	Supply & Erection of stainless steel nuts & bolts	Watt	3.86	27473	106,046
9	24-50-a-03	Supply & Installation, Testing and Commissioning of Submersible Pump (ISO-9906 certified) coupled with Submersible Rewindable Electric Motor with AC winding and all accessories like MCU (equiped with UV/OV, dry run protection device, surge protection, phase reverse indicator) complete in all accessories i/c NRV, Pressure Gauge, Sluice Valve with appropriate Head and Discharge <b>25 HPs</b>	Set	454872	1	454,872
10	24-50-c-02	Supply & Installation of Submersible Plate Cable made of 99.9% copper, quoted with doule PVC as per DSS Standard 3/16 mm2	M	874.75	95	83,101
11	24-56-b	Supply & Fixing MS Column Pipe with flunges for Submersible Pump 3" (75 mm) Nominal Pipe Size 3/16" thick, 10' length	M	2341.8	90	210,762



12	24-30-c-06	Providing, Laying, Cutting, Jointing, Testing and Disinfecting high density polyethylene pipe HDPE ISO-4427 in trenches, complete in all respects except excavation. (63 mm dia) PN-12.5	M	509.96	70	35,697
13	24-30-c-03	Providing, Laying, Cutting, Jointing, Testing and Disinfecting high density polyethylene pipe HDPE ISO-4427 in trenches, complete in all respects except excavation. (32 mm dia) PN-12.5	M	203.19	90	18,287
14	03-25-c	Excavation in foundation of building, bridges etc: complete in hard soil or soft murum	M <sup>3</sup>	298.50	11.150	3328
15	06-05-f	Plain Cement Concrete (PCC) including placing, compacting, finishing and curing (Ratio 1:2:4).	M <sup>3</sup>	7783.07	9.557	74383
<b>Total</b>						<b>4,392,080</b>
<b>Add Cost Factor 1.05</b>						<b>4,611,684</b>
<b>Say Million Rs.</b>						<b>4.612</b>
Note: Following information is to be provided by the bidder otherwise bid shall be declared as non-responsive (must be duly supported by evidence of exemption).						
Amount exempted from Federal GST (PKR):						
Amount chargeable to 17% Federal (FBR) sales tax on goods (PKR):						
Federal (FBR) sales tax on goods @ 17% (PKR):						
Amount chargeable to _____% Provincial (KPPRA) sales tax on services (PKR):						
Provincial (KPPRA) sales tax on services @ _____ % (PKR):						

**Note:-**

**Any other item of work crop out during execution will be paid on M.R.S 2020. The Quantities are liable to be increased or decreased during execution.**

Contractor Premium S.I \_\_\_\_\_ % Above /Below

Contractor Premium N.S.I \_\_\_\_\_ % Above/ Below

**Contractor Signature** \_\_\_\_\_

**Sub Engineer,**

**Sub Divisional Officer  
Irrigation & Hydle Division  
Tribal District North Waziristan**

# Bill of Quantity

**Name of Scheme:** Need Assessment and Construction of New Solar Tube Wells & Solarization of Existing Tube Wells (AIP). ADP No. 2325 / 195196 (2021-22).

**Sub Scheme:** Construction of New Solar Based Irrigation Tube Well at Tarkha, Waheed Kot Haider Khel Village Tehsil Mirali NWTD.(Solarization of Tube Well)

S.No	S. Item Code MRS 2020	Items Description	Unit	Unit Rate (Rs.) including installation price (A)	Quantity (B)	Total Amount (Rs.) (AXB)
1	26-01-d-01	Supply & Erection of Solar PV module (Solar Panel) Mono-crystalline A-Grade (Per Watt) (as per approved specification)	Watt	72.58	23473	1,703,670
2	26-01-b-02	Supply & Erection of PVC flexible pipe "1.5 i/d.	M	357.37	50	17,869
3	26-01-g-04	Supply & Erection 1X10 sq. mm flexible copper cable	M	349.84	70	24,489
4	26-01-h-01	Supply & Erection MC4 connector (TUV approved)	Pair	270.07	18	4,861
5	26-01-i-03-b	Supply and Erection of GRID TIE INVERTER(ON-Grid Inverter) (10-20 KW)	Watt	24.04	23473	564,291
6	26-01-m-01	Supply & Erection of hot dipped (80 microns Average) galvanised steel of minimum thickness of 12 SWG/2.64 mm channel/pipe or 8 SWG/4.06 mm angle.	Watt	21.82	23473	512,181
7	26-01-n-02	Supply & Erection of 1x1 ft 4 mm Copper Earthing Plate	Watt	3.86	23473	90,606
8	26-01-n-03	Supply & Erection of stainless steel nuts & bolts	Watt	3.86	23473	90,606
9	24-50-a-03	Supply & Installation, Testing and Commissioning of Submersible Pump (ISO-9906 certified) coupled with Submersible Rewindable Electric Motor with AC winding and all accessories like MCU (equipped with UV/OV, dry run protection device, surge protection, phase reverse indicator) complete in all accessories i/c NRV, Pressure Gauge, Sluice Valve with appropriate Head and Discharge <b>25 HPs</b>	Set	454872	1	454,872
10	24-50-c-02	Supply & Installation of Submersible Plate Cable made of 99.9% copper, quoted with double PVC as per DSS Standard 3/16 mm2	M	874.75	110	96,223
11	24-56-b	Supply & Fixing MS Column Pipe with flanges for Submersible Pump 3" (75 mm) Nominal Pipe Size 3/16" thick, 10' length	M	2341.8	95	222,471

12	24-30-c-06	Providing, Laying, Cutting, Jointing, Testing and Disinfecting high density polyethylene pipe HDPE ISO-4427 in trenches, complete in all respects except excavation. (63 mm dia) PN-12.5	M	509.96	72	36,717
13	24-30-c-03	Providing, Laying, Cutting, Jointing, Testing and Disinfecting high density polyethylene pipe HDPE ISO-4427 in trenches, complete in all respects except excavation. (32 mm dia) PN-12.5	M	203.19	80	16,255
14	03-25-c	Excavation in foundation of building, bridges etc: complete in hard soil or soft murum	M <sup>3</sup>	298.50	11.150	3328
15	06-05-f	Plain Cement Concrete (PCC) including placing, compacting, finishing and curing (Ratio 1:2:4).	M <sup>3</sup>	7783.07	9.557	74383
<b>Total</b>						<b>3,912,821</b>
<b>Add Cost Factor 1.05</b>						<b>4,108,462</b>
<b>Say Million Rs.</b>						<b>4.108</b>
Note: Following information is to be provided by the bidder otherwise bid shall be declared as non-responsive (must be duly supported by evidence of exemption).						
Amount exempted from Federal GST (PKR):						
Amount chargeable to 17% Federal (FBR) sales tax on goods (PKR):						
Federal (FBR) sales tax on goods @ 17% (PKR):						
Amount chargeable to _____% Provincial (KPPRA) sales tax on services (PKR):						
Provincial (KPPRA) sales tax on services @ _____ % (PKR):						

**Note:-**

**Any other item of work crop out during execution will be paid on M.R.S 2020. The Quantities are liable to be increased or decreased during execution.**

Contractor Premium S.I \_\_\_\_\_ % Above /Below

Contractor Premium N.S.I \_\_\_\_\_ % Above/ Below

**Contractor Signature** \_\_\_\_\_

**Sub Engineer,**

**Sub Divisional Officer  
Irrigation & Hydle Division  
Tribal District North Waziristan**

# Bill of Quantity

**Name of Scheme:** Need Assessment and Construction of New Solar Tube Wells & Solarization of Existing Tube Wells (AIP). ADP No. 2325 / 195196 (2021-22).

**Sub Scheme:** Construction of New Solar Based Irrigation Tube Well at Bada Khel Faqir Fazal Rahman Kot Tehsil Shewa NWTD. (Solarization of Tube Well)

S.No	S. Item Code MRS 2020	Items Description	Unit	Unit Rate (Rs.) including installation price (A)	Quantity (B)	Total Amount (Rs.) (AXB)
1	26-01-d-01	Supply & Erection of Solar PV module (Solar Panel) Mono-crystalline A-Grade (Per Watt) (as per approved specification)	Watt	72.58	21000	1,524,180
2	26-01-b-02	Supply & Erection of PVC flexible pipe "1.5 i/d.	M	357.37	50	17,869
3	26-01-g-04	Supply & Erection 1X10 sq. mm flexible copper cable	M	349.84	70	24,489
4	26-01-h-01	Supply & Erection MC4 connector (TUV approved)	Pair	270.07	18	4,861
5	26-01-i-03-b	Supply and Erection of GRID TIE INVERTER(ON-Grid Inverter) (10-20 KW)	Watt	24.04	21000	504,840
6	26-01-m-01	Supply & Erection of hot dipped (80 microns Average) galvanised steel of minimum thickness of 12 SWG/2.64 mm channel/pipe or 8 SWG/4.06 mm angle.	Watt	21.82	21000	458,220
7	26-01-n-02	Supply & Erection of 1x1 ft 4 mm Copper Earthing Plate	Watt	3.86	21000	81,060
8	26-01-n-03	Supply & Erection of stainless steel nuts & bolts	Watt	3.86	21000	81,060
9	24-50-a-03	Supply & Installation, Testing and Commissioning of Submersible Pump (ISO-9906 certified) coupled with Submersible Rewindable Electric Motor with AC winding and all accessories like MCU (equiped with UV/OV, dry run protection device, surge protection, phase reverse indicator) complete in all accessories i/c NRV, Pressure Gauge, Sluice Valve with appropriate Head and Discharge <b>25 HPs</b>	Set	454872	1	454,872
10	24-50-c-02	Supply & Installation of Submersible Plate Cable made of 99.9% copper, quoted with doule PVC as per DSS Standard 3/16 mm2	M	874.75	110	96,223
11	24-56-b	Supply & Fixing MS Column Pipe with flunges for Submersible Pump 3" (75 mm) Nominal Pipe Size 3/16" thick, 10' length	M	2341.8	95	222,471

12	24-30-c-06	Providing, Laying, Cutting, Jointing, Testing and Disinfecting high density polyethylene pipe HDPE ISO-4427 in trenches, complete in all respects except excavation. (63 mm dia) PN-12.5	M	509.96	72	36,717
13	24-30-c-03	Providing, Laying, Cutting, Jointing, Testing and Disinfecting high density polyethylene pipe HDPE ISO-4427 in trenches, complete in all respects except excavation. (32 mm dia) PN-12.5	M	203.19	80	16,255
14	03-25-c	Excavation in foundation of building, bridges etc: complete in hard soil or soft murum	M <sup>3</sup>	298.50	11.150	3328
15	06-05-f	Plain Cement Concrete (PCC) including placing, compacting, finishing and curing (Ratio 1:2:4).	M <sup>3</sup>	7783.07	9.557	74383
<b>Total</b>						<b>3,600,827</b>
<b>Add Cost Factor 1.07</b>						<b>3,852,885</b>
<b>Say Million Rs.</b>						<b>3.853</b>
Note: Following information is to be provided by the bidder otherwise bid shall be declared as non-responsive (must be duly supported by evidence of exemption).						
Amount exempted from Federal GST (PKR):						
Amount chargeable to 17% Federal (FBR) sales tax on goods (PKR):						
Federal (FBR) sales tax on goods @ 17% (PKR):						
Amount chargeable to _____% Provincial (KPPRA) sales tax on services (PKR):						
Provincial (KPPRA) sales tax on services @ _____ % (PKR):						

**Note:-**

**Any other item of work crop out during execution will be paid on M.R.S 2020. The Quantities are liable to be increased or decreased during execution.**

Contractor Premium S.I \_\_\_\_\_ % Above /Below

Contractor Premium N.S.I \_\_\_\_\_ % Above/ Below

**Contractor Signature** \_\_\_\_\_

**Sub Engineer,**

**Sub Divisional Officer  
Irrigation & Hydle Division  
Tribal District North Waziristan**

# Bill of Quantity

**Name of Scheme:** Need Assessment and Construction of New Solar Tube Wells & Solarization of Existing Tube Wells (AIP). ADP No. 2325 / 195196 (2021-22).

**Sub Scheme:** Construction of New Solar Based Irrigation Tube Well at Bakhtawar Kot Tehsil Shewa NWTD. (Solarization of Tube Well)

S.No	S. Item Code MRS 2020	Items Description	Unit	Unit Rate (Rs.) including installation price (A)	Quantity (B)	Total Amount (Rs.) (AXB)
1	26-01-d-01	Supply & Erection of Solar PV module (Solar Panel) Mono-crystalline A-Grade (Per Watt) (as per approved specification)	Watt	72.58	23473	1,703,670
2	26-01-b-02	Supply & Erection of PVC flexible pipe "1.5 i/d.	M	357.37	50	17,869
3	26-01-g-04	Supply & Erection 1X10 sq. mm flexible copper cable	M	349.84	70	24,489
4	26-01-h-01	Supply & Erection MC4 connector (TUV approved)	Pair	270.07	18	4,861
5	26-01-i-03-b	Supply and Erection of GRID TIE INVERTER(ON-Grid Inverter) (10-20 KW)	Watt	24.04	23473	564,291
6	26-01-m-01	Supply & Erection of hot dipped (80 microns Average) galvanised steel of minimum thickness of 12 SWG/2.64 mm channel/pipe or 8 SWG/4.06 mm angle.	Watt	21.82	23473	512,181
7	26-01-n-02	Supply & Erection of 1x1 ft 4 mm Copper Earthing Plate	Watt	3.86	23473	90,606
8	26-01-n-03	Supply & Erection of stainless steel nuts & bolts	Watt	3.86	23473	90,606
9	24-50-a-03	Supply & Installation, Testing and Commissioning of Submersible Pump (ISO-9906 certified) coupled with Submersible Rewindable Electric Motor with AC winding and all accessories like MCU (equipped with UV/OV, dry run protection device, surge protection, phase reverse indicator) complete in all accessories i/c NRV, Pressure Gauge, Sluice Valve with appropriate Head and Discharge <b>25</b> HPs	Set	454872	1	454,872
10	24-50-c-02	Supply & Installation of Submersible Plate Cable made of 99.9% copper, quoted with double PVC as per DSS Standard 3/16 mm2	M	874.75	110	96,223
11	24-56-b	Supply & Fixing MS Column Pipe with flanges for Submersible Pump 3" (75 mm) Nominal Pipe Size 3/16" thick, 10' length	M	2341.8	95	222,471

12	24-30-c-06	Providing, Laying, Cutting, Jointing, Testing and Disinfecting high density polyethylene pipe HDPE ISO-4427 in trenches, complete in all respects except excavation. (63 mm dia) PN-12.5	M	509.96	72	36,717
13	24-30-c-03	Providing, Laying, Cutting, Jointing, Testing and Disinfecting high density polyethylene pipe HDPE ISO-4427 in trenches, complete in all respects except excavation. (32 mm dia) PN-12.5	M	203.19	80	16,255
14	03-25-c	Excavation in foundation of building, bridges etc: complete in hard soil or soft murum	M <sup>3</sup>	298.50	11.150	3328
15	06-05-f	Plain Cement Concrete (PCC) including placing, compacting, finishing and curing (Ratio 1:2:4).	M <sup>3</sup>	7783.07	9.557	74383
<b>Total</b>						<b>3,912,821</b>
<b>Add Cost Factor 1.07</b>						<b>4,186,719</b>
<b>Say Million Rs.</b>						<b>4.187</b>
Note: Following information is to be provided by the bidder otherwise bid shall be declared as non-responsive (must be duly supported by evidence of exemption).						
Amount exempted from Federal GST (PKR):						
Amount chargeable to 17% Federal (FBR) sales tax on goods (PKR):						
Federal (FBR) sales tax on goods @ 17% (PKR):						
Amount chargeable to _____% Provincial (KPPRA) sales tax on services (PKR):						
Provincial (KPPRA) sales tax on services @ _____ % (PKR):						

**Note:-**

**Any other item of work crop out during execution will be paid on M.R.S 2020. The Quantities are liable to be increased or decreased during execution.**

Contractor Premium S.I \_\_\_\_\_ % Above /Below

Contractor Premium N.S.I \_\_\_\_\_ % Above/ Below

**Contractor Signature** \_\_\_\_\_

**Sub Engineer,**

**Sub Divisional Officer  
Irrigation & Hydle Division  
Tribal District North Waziristan**

# Bill of Quantity

**Name of Scheme:** Need Assessment and Construction of New Solar Tube Wells & Solarization of Existing Tube Wells (AIP). ADP No. 2325 / 195196 (2021-22).

**Sub Scheme:** Construction of New Solar Based Irrigation Tube Well at Havat Ullah Kassa Shiratalla Tehsil Spinwam NWTD. (Solarization of Tube Well)

S.No	S. Item Code MRS 2020	Items Description	Unit	Unit Rate (Rs.) including installation price (A)	Quantity (B)	Total Amount (Rs.) (AXB)
1	26-01-d-01	Supply & Erection of Solar PV module (Solar Panel) Mono-crystalline A-Grade (Per Watt) (as per approved specification)	Watt	72.58	22200	1,611,276
2	26-01-b-02	Supply & Erection of PVC flexible pipe "1.5 i/d.	M	357.37	50	17,869
3	26-01-g-04	Supply & Erection 1X10 sq. mm flexible copper cable	M	349.84	70	24,489
4	26-01-h-01	Supply & Erection MC4 connector (TUV approved)	Pair	270.07	18	4,861
5	26-01-i-03-b	Supply and Erection of GRID TIE INVERTER(ON-Grid Inverter) (10-20 KW)	Watt	24.04	22200	533,688
6	26-01-m-01	Supply & Erection of hot dipped (80 microns Average) galvanised steel of minimum thickness of 12 SWG/2.64 mm channel/pipe or 8 SWG/4.06 mm angle.	Watt	21.82	22200	484,404
7	26-01-n-02	Supply & Erection of 1x1 ft 4 mm Copper Earthing Plate	Watt	3.86	22200	85,692
8	26-01-n-03	Supply & Erection of stainless steel nuts & bolts	Watt	3.86	22200	85,692
9	24-50-a-03	Supply & Installation, Testing and Commissioning of Submersible Pump (ISO-9906 certified) coupled with Submersible Rewindable Electric Motor with AC winding and all accessories like MCU (equiped with UV/OV, dry run protection device, surge protection, phase reverse indicator) complete in all accessories i/c NRV, Pressure Gauge, Sluice Valve with appropriate Head and Discharge <b>25 HPs</b>	Set	454872	1	454,872
10	24-50-c-02	Supply & Installation of Submersible Plate Cable made of 99.9% copper, quoted with doule PVC as per DSS Standard 3/16 mm2	M	874.75	110	96,223
11	24-56-b	Supply & Fixing MS Column Pipe with flunges for Submersible Pump 3" (75 mm) Nominal Pipe Size 3/16" thick, 10' length	M	2341.8	95	222,471



12	24-30-c-06	Providing, Laying, Cutting, Jointing, Testing and Disinfecting high density polyethylene pipe HDPE ISO-4427 in trenches, complete in all respects except excavation. (63 mm dia) PN-12.5	M	509.96	72	36,717
13	24-30-c-03	Providing, Laying, Cutting, Jointing, Testing and Disinfecting high density polyethylene pipe HDPE ISO-4427 in trenches, complete in all respects except excavation. (32 mm dia) PN-12.5	M	203.19	80	16,255
14	03-25-c	Excavation in foundation of building, bridges etc: complete in hard soil or soft murum	M <sup>3</sup>	298.50	11.150	3328
15	06-05-f	Plain Cement Concrete (PCC) including placing, compacting, finishing and curing (Ratio 1:2:4).	M <sup>3</sup>	7783.07	9.557	74383
<b>Total</b>						<b>3,752,219</b>
<b>Add Cost Factor 1.07</b>						<b>4,014,875</b>
<b>Say Million Rs.</b>						<b>4.015</b>
Note: Following information is to be provided by the bidder otherwise bid shall be declared as non-responsive (must be duly supported by evidence of exemption).						
Amount exempted from Federal GST (PKR):						
Amount chargeable to 17% Federal (FBR) sales tax on goods (PKR):						
Federal (FBR) sales tax on goods @ 17% (PKR):						
Amount chargeable to _____% Provincial (KPPRA) sales tax on services (PKR):						
Provincial (KPPRA) sales tax on services @ _____ % (PKR):						

**Note:-**

**Any other item of work crop out during execution will be paid on M.R.S 2020. The Quantities are liable to be increased or decreased during execution.**

Contractor Premium S.I \_\_\_\_\_ % Above /Below

Contractor Premium N.S.I \_\_\_\_\_ % Above/ Below

**Contractor Signature** \_\_\_\_\_

**Sub Engineer,**

**Sub Divisional Officer  
Irrigation & Hydle Division  
Tribal District North Waziristan**

# Bill of Quantity

**Name of Scheme:** Need Assessment and Construction of New Solar Tube Wells & Solarization of Existing Tube Wells (AIP). ADP No. 2325 / 195196 (2021-22).

**Sub Scheme:** Construction of New Solar Based Irrigation Tube Well at Kotka Kabir Khan Village Mullagan Tehsil Mirali NWT.D. (Solarization of Tube Well)

S.No	S. Item Code MRS 2020	Items Description	Unit	Unit Rate (Rs.) including installation price (A)	Quantity (B)	Total Amount (Rs.) (AXB)
1	26-01-d-01	Supply & Erection of Solar PV module (Solar Panel) Mono-crystalline A-Grade (Per Watt) (as per approved specification)	Watt	72.58	23473	1,703,670
2	26-01-b-02	Supply & Erection of PVC flexible pipe "1.5 i/d.	M	357.37	50	17,869
3	26-01-g-04	Supply & Erection 1X10 sq. mm flexible copper cable	M	349.84	70	24,489
4	26-01-h-01	Supply & Erection MC4 connector (TUV approved)	Pair	270.07	18	4,861
5	26-01-i-03-b	Supply and Erection of GRID TIE INVERTER(ON-Grid Inverter) (10-20 KW)	Watt	24.04	23473	564,291
6	26-01-m-01	Supply & Erection of hot dipped (80 microns Average) galvanised steel of minimum thickness of 12 SWG/2.64 mm channel/pipe or 8 SWG/4.06 mm angle.	Watt	21.82	23473	512,181
7	26-01-n-02	Supply & Erection of 1x1 ft 4 mm Copper Earthing Plate	Watt	3.86	23473	90,606
8	26-01-n-03	Supply & Erection of stainless steel nuts & bolts	Watt	3.86	23473	90,606
9	24-50-a-03	Supply & Installation, Testing and Commissioning of Submersible Pump (ISO-9906 certified) coupled with Submersible Rewindable Electric Motor with AC winding and all accessories like MCU (equiped with UV/OV, dry run protection device, surge protection, phase reverse indicator) complete in all accessories i/c NRV, Pressure Gauge, Sluice Valve with appropriate Head and Discharge <b>25 HPs</b>	Set	454872	1	454,872
10	24-50-c-02	Supply & Installation of Submersible Plate Cable made of 99.9% copper, quoted with doule PVC as per DSS Standard 3/16 mm2	M	874.75	110	96,223
11	24-56-b	Supply & Fixing MS Column Pipe with flunges for Submersible Pump 3" (75 mm) Nominal Pipe Size 3/16" thick, 10' length	M	2341.8	95	222,471

12	24-30-c-06	Providing, Laying, Cutting, Jointing, Testing and Disinfecting high density polyethylene pipe HDPE ISO-4427 in trenches, complete in all respects except excavation. (63 mm dia) PN-12.5	M	509.96	72	36,717
13	24-30-c-03	Providing, Laying, Cutting, Jointing, Testing and Disinfecting high density polyethylene pipe HDPE ISO-4427 in trenches, complete in all respects except excavation. (32 mm dia) PN-12.5	M	203.19	80	16,255
14	03-25-c	Excavation in foundation of building, bridges etc: complete in hard soil or soft murum	M <sup>3</sup>	298.50	11.150	3328
15	06-05-f	Plain Cement Concrete (PCC) including placing, compacting, finishing and curing (Ratio 1:2:4).	M <sup>3</sup>	7783.07	9.557	74383
<b>Total</b>						<b>3,912,821</b>
<b>Add Cost Factor 1.05</b>						<b>4,108,462</b>
<b>Say Million Rs.</b>						<b>4.108</b>
Note: Following information is to be provided by the bidder otherwise bid shall be declared as non-responsive (must be duly supported by evidence of exemption).						
Amount exempted from Federal GST (PKR):						
Amount chargeable to 17% Federal (FBR) sales tax on goods (PKR):						
Federal (FBR) sales tax on goods @ 17% (PKR):						
Amount chargeable to _____% Provincial (KPPRA) sales tax on services (PKR):						
Provincial (KPPRA) sales tax on services @ _____ % (PKR):						

**Note:-**

**Any other item of work crop out during execution will be paid on M.R.S 2020. The Quantities are liable to be increased or decreased during execution.**

Contractor Premium S.I \_\_\_\_\_ % Above /Below

Contractor Premium N.S.I \_\_\_\_\_ % Above/ Below

**Contractor Signature** \_\_\_\_\_

**Sub Engineer,**

**Sub Divisional Officer  
Irrigation & Hydle Division  
Tribal District North Waziristan**

# Bill of Quantity

**Name of Scheme:** Need Assessment and Construction of New Solar Tube Wells & Solarization of Existing Tube Wells (AIP). ADP No. 2325 / 195196 (2021-22).

**Sub Scheme:** Construction of New Solar Based Irrigation Tube Well at Kotka Arshad Khan Village Musaki Tehsil Mirali NWT D (Solarization of Tube Well).

S.No	S. Item Code MRS 2020	Items Description	Unit	Unit Rate (Rs.) including installation price (A)	Quantity (B)	Total Amount (Rs.) (AXB)
1	26-01-d-01	Supply & Erection of Solar PV module (Solar Panel) Mono-crystalline A-Grade (Per Watt) (as per approved specification)	Watt	72.58	23473	1,703,670
2	26-01-b-02	Supply & Erection of PVC flexible pipe "1.5 i/d.	M	357.37	50	17,869
3	26-01-g-04	Supply & Erection 1X10 sq. mm flexible copper cable	M	349.84	70	24,489
4	26-01-h-01	Supply & Erection MC4 connector (TUV approved)	Pair	270.07	18	4,861
5	26-01-i-03-b	Supply and Erection of GRID TIE INVERTER(ON-Grid Inverter) (10-20 KW)	Watt	24.04	23473	564,291
6	26-01-m-01	Supply & Erection of hot dipped (80 microns Average) galvanised steel of minimum thickness of 12 SWG/2.64 mm channel/pipe or 8 SWG/4.06 mm angle.	Watt	21.82	23473	512,181
7	26-01-n-02	Supply & Erection of 1x1 ft 4 mm Copper Earthing Plate	Watt	3.86	23473	90,606
8	26-01-n-03	Supply & Erection of stainless steel nuts & bolts	Watt	3.86	23473	90,606
9	24-50-a-03	Supply & Installation, Testing and Commissioning of Submersible Pump (ISO-9906 certified) coupled with Submersible Rewindable Electric Motor with AC winding and all accessories like MCU (equipped with UV/OV, dry run protection device, surge protection, phase reverse indicator) complete in all accessories i/c NRV, Pressure Gauge, Sluice Valve with appropriate Head and Discharge <b>25 HPs</b>	Set	454872	1	454,872
10	24-50-c-02	Supply & Installation of Submersible Plate Cable made of 99.9% copper, quoted with double PVC as per DSS Standard 3/16 mm <sup>2</sup>	M	874.75	110	96,223
11	24-56-b	Supply & Fixing MS Column Pipe with flanges for Submersible Pump 3" (75 mm) Nominal Pipe Size 3/16" thick, 10' length	M	2341.8	95	222,471

12	24-30-c-06	Providing, Laying, Cutting, Jointing, Testing and Disinfecting high density polyethylene pipe HDPE ISO-4427 in trenches, complete in all respects except excavation. (63 mm dia) PN-12.5	M	509.96	72	36,717
13	24-30-c-03	Providing, Laying, Cutting, Jointing, Testing and Disinfecting high density polyethylene pipe HDPE ISO-4427 in trenches, complete in all respects except excavation. (32 mm dia) PN-12.5	M	203.19	80	16,255
14	03-25-c	Excavation in foundation of building, bridges etc: complete in hard soil or soft murum	M <sup>3</sup>	298.50	11.150	3328
15	06-05-f	Plain Cement Concrete (PCC) including placing, compacting, finishing and curing (Ratio 1:2:4).	M <sup>3</sup>	7783.07	9.557	74383
<b>Total</b>						<b>3,912,821</b>
<b>Add Cost Factor 1.05</b>						<b>4,108,462</b>
<b>Say Million Rs.</b>						<b>4.108</b>
Note: Following information is to be provided by the bidder otherwise bid shall be declared as non-responsive (must be duly supported by evidence of exemption).						
Amount exempted from Federal GST (PKR):						
Amount chargeable to 17% Federal (FBR) sales tax on goods (PKR):						
Federal (FBR) sales tax on goods @ 17% (PKR):						
Amount chargeable to _____% Provincial (KPPRA) sales tax on services (PKR):						
Provincial (KPPRA) sales tax on services @ _____ % (PKR):						

**Note:-**

**Any other item of work crop out during execution will be paid on M.R.S 2020. The Quantities are liable to be increased or decreased during execution.**

Contractor Premium S.I \_\_\_\_\_ % Above /Below

Contractor Premium N.S.I \_\_\_\_\_ % Above/ Below

**Contractor Signature** \_\_\_\_\_

**Sub Engineer,**

**Sub Divisional Officer  
Irrigation & Hydle Division  
Tribal District North Waziristan**

# Bill of Quantity

**Name of Scheme:** Need Assessment and Construction of New Solar Tube Wells & Solarization of Existing Tube Wells (AIP). ADP No. 2325 / 195196 (2021-22).

**Sub Scheme:** Construction of New Solar Based Irrigation Tube Well at Shab Nawaz Rocha Bakka Khel Sub Division Wazir Bannu. (Solarization of Tube Well)

S.No	S. Item Code MRS 2020	Items Description	Unit	Unit Rate (Rs.) including installation price (A)	Quantity (B)	Total Amount (Rs.) (AXB)
1	26-01-d-01	Supply & Erection of Solar PV module (Solar Panel) Mono-crystalline A-Grade (Per Watt) (as per approved specification)	Watt	72.58	36631	2,658,678
2	26-01-b-02	Supply & Erection of PVC flexible pipe "1.5 i/d.	M	357.37	30	10,721
3	26-01-g-04	Supply & Erection 1X10 sq. mm flexible copper cable	M	349.84	100	34,984
4	26-01-h-01	Supply & Erection MC4 connector (TUV approved)	Pair	270.07	15	4,051
5	26-01-i-03-b	Supply and Erection of GRID TIE INVERTER(ON-Grid Inverter) (10-20 KW)	Watt	24.04	36631	880,609
6	26-01-m-01	Supply & Erection of hot dipped (80 microns Average) galvanised steel of minimum thickness of 12 SWG/2.64 mm channel/pipe or 8 SWG/4.06 mm angle.	Watt	21.82	36631	799,288
7	26-01-n-02	Supply & Erection of 1x1 ft 4 mm Copper Earthing Plate	Watt	3.86	36631	141,396
8	26-01-n-03	Supply & Erection of stainless steel nuts & bolts	Watt	3.86	36631	141,396
9	24-50-a-03	Supply & Installation, Testing and Commissioning of Submersible Pump (ISO-9906 certified) coupled with Submersible Rewindable Electric Motor with AC winding and all accessories like MCU (equiped with UV/OV, dry run protection device, surge protection, phase reverse indicator) complete in all accessories i/c NRV, Pressure Gauge, Sluice Valve with appropriate Head and Discharge <b>25 HPs</b>	Set	454872	1	454,872
10	24-50-c-02	Supply & Installation of Submersible Plate Cable made of 99.9% copper, quoted with doule PVC as per DSS Standard 3/16 mm2	M	874.75	120	104,970
11	24-56-b	Supply & Fixing MS Column Pipe with flunges for Submersible Pump 3" (75 mm) Nominal Pipe Size 3/16" thick, 10' length	M	2341.8	120	281,016

12	24-30-c-06	Providing, Laying, Cutting, Jointing, Testing and Disinfecting high density polyethylene pipe HDPE ISO-4427 in trenches, complete in all respects except excavation. (63 mm dia) PN-12.5	M	509.96	100	50,996
13	24-30-c-03	Providing, Laying, Cutting, Jointing, Testing and Disinfecting high density polyethylene pipe HDPE ISO-4427 in trenches, complete in all respects except excavation. (32 mm dia) PN-12.5	M	203.19	100	20,319
14	03-25-c	Excavation in foundation of building, bridges etc: complete in hard soil or soft murum	M <sup>3</sup>	298.50	11.150	3328
15	06-05-f	Plain Cement Concrete (PCC) including placing, compacting, finishing and curing (Ratio 1:2:4).	M <sup>3</sup>	7783.07	9.557	74383
<b>Total</b>						<b>5,661,007</b>
<b>Add Cost Factor 1.03</b>						<b>5,830,837</b>
<b>Say Million Rs.</b>						<b>5.831</b>
Note: Following information is to be provided by the bidder otherwise bid shall be declared as non-responsive (must be duly supported by evidence of exemption).						
Amount exempted from Federal GST (PKR):						
Amount chargeable to 17% Federal (FBR) sales tax on goods (PKR):						
Federal (FBR) sales tax on goods @ 17% (PKR):						
Amount chargeable to _____% Provincial (KPPRA) sales tax on services (PKR):						
Provincial (KPPRA) sales tax on services @ _____ % (PKR):						

**Note:-**

**Any other item of work crop out during execution will be paid on M.R.S 2020. The Quantities are liable to be increased or decreased during execution.**

Contractor Premium S.I \_\_\_\_\_ % Above /Below

Contractor Premium N.S.I \_\_\_\_\_ % Above/ Below

**Contractor Signature** \_\_\_\_\_

**Sub Engineer,**

**Sub Divisional Officer  
Irrigation & Hydle Division  
Tribal District North Waziristan**



GOVERNMENT OF KHYBER PAKHTUNKHWA  
COMMUNICATION & WORKS DEPARTMENT  
NO.SO(B)/II-10/Standardization//Solar Panels/PBC/2018-19/C&WD  
Dated Peshawar the: 29/01/2019

To

1. Additional Secretary (Admn / Coord), FATA Secretariat Warsak Road Peshawar.
2. Director General M&E P&D Department, Peshawar.
3. Director Agriculture Engineering Tarnab Farm Peshawar.
4. Superintending Engineer, PHE Division Mardan, PHE Department.
5. Superintending Engineer PBC, C&W Department, Peshawar.
6. Director General PDA.
7. Chairman Electrical Engineering Department, University of Engineering & Technology Peshawar.
8. Executive Engineer Warsak Canal Division Peshawar, Irrigation Department.
9. Executive Engineer, Peshawar Division, PHE Department.
10. Deputy Director (PHA), ATI Campus Jamrod road Peshawar.
11. Executive Engineer PBC-II C&W Department.
12. Planning Officer, LG&RD Department.
13. Assistant Engr. CSR / MRS (Cell) C&W Department.
14. Manager Energy & Power Department Peshawar.
15. Deputy Secretary (Technical), Public Health Engineering Department, Peshawar.

Subject: REVISED TECHNICAL SPECIFICATIONS FOR SOLAR PANELS AND ALLIED EQUIPMENT (REV 2018).

I am directed to refer to the subject noted above and to enclose herewith approved Minutes of the standardization of revised technical specification for solar panels and allied equipment's (Rev 2018) meeting held on 11/01/2019 at 10:30 AM under the Chairmanship of Secretary C&W Department along with approved "Revised specifications for supply and installations of 1).Solar Based Pumping System 2).Solar Buildings / Home Systems 3).Solar Street Lights", duly approved by Standardization Committee of Khyber Pakhtunkhwa and approved pre-qualification proforma of solar panels for information and necessary action at your end, please.

  
(Engr. Muhammad Imran)  
Section Officer (Buildings)

Endst: No. & Date Even:

Copy is forwarded for information to the:-

1. Chairman Pakistan Engineering Council (PEC) Building, Attaturk Avenue (East) G-5/2 P.O Box 1296, Islamabad.
2. Director Solar, Alternative Energy Development Board, Ministry of Energy / Power Division, Government of Pakistan, 2<sup>nd</sup> Floor, OPF Building, Shahrah e Jamhuriat, G5/2, Islamabad.
3. Manager Technical, National Energy Efficiency & Conservation Authority (NEECA), Near State Bank of Pakistan, NEECA Building, Sector G5/2, Islamabad.
4. Director Standards, Pakistan Standards & quality Control Authority, PSQCA Complex, Plot No. ST-7/A, Block No. 3 Scheme No. 36, Near Kamran Chowrangi, Gulistan E Jauhar, Karachi.
5. Member Custom Policy, Federal Board of Revenue (FBR), FBR House / Building, Opposite Supreme Court of Pakistan, Islamabad.
6. PS to Secretary C&W Department Peshawar.

  
Section Officer (Buildings)

**Note:** "Revised specifications for supply and installations of 1).Solar Based Pumping System 2).Solar Buildings / Home Systems 3).Solar Street Lights" is uploaded on C&W Department official website i-e [cwd.gov.pk](http://cwd.gov.pk) for easy receipt of the same.



**MINUTES OF THE STANDARDIZATION OF REVISED TECHNICAL SPECIFICATION FOR SOLAR PANELS AND ALLIED EQUIPMENT'S (REV 2018).**

A meeting of the committee regarding Standardization of Solar Panels & other allied works for the use in public infrastructure was held on 11/01/2019 at 10:30 AM under the chairmanship of Secretary C&W Department in the committee room of this Department (*List of participants attached*).

The meeting started with the recitation from the Holy Quran. While opening of discussion the Secretary C&W Department welcomed the participants and the Deputy Secretary (Technical) was asked to inform the forum regarding solar specifications.

The forum was briefed regarding the specification prepared by the sub-committee in its meeting held on 08/01/2019 under the chairmanship of Deputy Secretary (Technical) Public Health Engineering Department. Each and every item of Solar Panel with the allied equipment's have been discussed in detail certain changes proposed by the member were incorporated in the specification presented by the Chairman of the sub-committee. After detail deliberation the specification were approved unanimously and it was further decided to notify these specification in the best interest of public work keeping in view the works already approved or in the process of tendering which has been based on the previous specification notified vide No. SO(B)/II-10/Standardization/PBC/2016-17/C&WD dated 23/06/2017 to facilitate the executing agency in a right direction, therefore a gap of 3 months be kept in the implementation process. Hence these specification would be applicable which are to be tendered on or after 01/04/2019

**Meeting ended with vote of thanks.**

PS

### LIST OF PARTICIPANTS

UP GRADATION IN APPROVED SPECIFICATIONS OF SOLAR PANELS COMMITTEE  
MEETING SCHEDULED TO BE HELD ON 11/12/2018 AT 10:30 AM.

SUB HEAD: REVISED TECHNICAL SPECIFICATION FOR SOLAR PANELS AND  
ALLIED EQUIPMENT'S (REV 2018).

S.No.	Name of Officer/Official	Designation	Department	Signature
1.	Engr. Shahab Khattak	Secretary	C&W	
2.	ISHTIYAZ AHMAD	Assistant Engineer C&W/MSCell	C&W	
3.	Amin-Zeb	Director	Housing	
4.	Sami-ullah Kundi	Xen	Irrigation	
5.	Jehanzeb Khan	SDO	Irrigat.	
6.	Engr. Nasir Zaman Khan	SO (Tech)	PH&Dept	
7.	Engr. M. Amjad Khan	DST (Tech)	PH&D	
8.	Mahmoodulhaq Baloch	Director	Agri Engr	
9.	Engr. Parvez Zaman	Superintending Engineer	PH&D	
10.	Engr. Babar Nawaz	Assistant Director	M&E System, PH&D	
11.	Engr. Khuram Durrani	PO	Energy & Power Dept	
12.	Engr. Salman	Dy. Director	PDAC (Elect)	
13.	SAUD KHAN	SO PRC-II	C&W	
14.				
15.				
16.				
17.				
18.				
19.				
20.				
21.				
22.				
23.				
24.				
25.				
26.				
27.				
28.				
29.				
30.				

**REVISED  
SPECIFICATIONS  
FOR  
SUPPLY AND INSTALLATIONS OF**

- 1. SOLAR BASED PUMPING SYSTEMS,**
- 2. SOLAR BUILDINGS / HOME SYSTEMS.**
- 3. SOLAR STREET LIGHTS**



**2019  
Version-01**

**APPROVED BY STANDARIZATION COMMITTEE OF  
KHYBER PAKHTUNKHWA**

*[Signature]*  
Executive Engineer  
Wamsak Canals Division  
Peshawar

*[Signature]*  
Superintending Engineer  
PHE Circle Tribal  
Districts Peshawar.

*[Signature]*  
PDA

*[Signature]*  
Deputy Secretary (Tech.)  
Public Health Engg. Department  
Khyber Pakhtunkhwa

*[Signature]*  
Assistant Director (M&E)

*[Signature]*  
PD Lt Depu

*[Signature]*  
DIRECTOR  
Agril: Engineering,  
Tarnab, Peshawar

*[Signature]*  
ATI  
PHT

*[Signature]*  
16/01/2019  
Assistant Engineer  
CSR/MRS Cell C&W  
Department

*[Signature]*

16/01/2019  
Chairman Electric & UED

*[Signature]*  
XEN PHE-IT  
*[Signature]*  
XEN (PHE)  
*[Signature]*  
ECP

*[Signature]*  
SEC (HE)  
CE (M.A.)



- q. The Inverter Junction Box should be properly earthed as well as per vetted design of the Engineer in charge.
- r. All wiring should be in proper conduit of capping casing. Wire should not be hanging loose.
- s. All wires should be terminated properly by using lugs / thimble connectors / sleeves.
- t. Distribution board must be installed with proper screws.
- u. Electrical Hazards Safety Labels should be pasted on DC Combiner /VFD Enclosure / Charge Controller /Battery Enclosures.
- v. Following lab tests are mandatory.  
Conductor resistance test, Insulation resistance test, Pressure test, Spark test.
- w. DC Cable from PV Module to Junction Box / Inverter for each string should be minimum-size 6 mm<sup>2</sup>.
- x. DC Cable sizing (For Pumping Schemes) from Junction Box to Inverter as per details below;

S. No	Nos of Strings	Cable Size ((mm <sup>2</sup> ))	Remarks
1	1	6	If Cable length is >200 ft (One Sided) than cable size should also be increased accordingly.
2	2	10	
3	3	16	
4	4-5	25	
5	6-8	35	

### 3. PANEL MOUNTING & STRUCTURE:

- a. The panel mounting and structure should be made of hot dipped (80 microns Average) galvanized steel of minimum thickness of **12 SWG / 2.64 mm Channel / Pipe or 8 SWG / 4.06 mm Angle** (Profile of channel and Sketch Attached for Reference).
- b. A sketch of the mounting frame (As per Actual Site Requirements) showing dimensions of the frame parts should be provided at the time of supply.
- c. PV to ground clearance must not be less than 1.5 feet. The height of the upper edge of the structure should not exceed 10 feet above the ground and 6 Feet for Roof Top Installations.
- d. To avoid Shading, Distance between two rows of PV panels and from walls should be maintained at a minimum of 1.6 times the height of structure/walls.  
The pit size for concrete works should be minimum 1.5x1.5x2 feet for each individual leg or 1.5x2.5x2 for double leg and the concrete should be extended at least 1 foot above the ground. The concrete ratio should be 1:2:4.
- f. The Surface azimuth angle of PV Module 180° and the Tilt angle (slope) of PV Module should be 33°.
- g. The PV modules will be mounted on metallic structures of adequate strength and appropriate design, which can withstand load of modules and high wind velocities up to 150 km per hour.
- h. Due to land Non-availability or any other problem, Structure design can be modified as per site requirement. Pole Mounted or manual Tracker Structure can be provided with the approval of Engineer In-charge.
- i. Array fasteners (nut/bolts/washers) between PV Module and Structure shall be stainless steel. Washers should be installed on both sides of Module frame.
- j. The minimum space between two PV Modules should be 2.54 cm (1 inch), to avoid air push over PV Modules.
- k. Mechanism / arrangement for cleaning of PV Panels should be provided. i.e: Space and ladder between panels or at the back side of structure, so that the operator can safely climb and clean the panels.
- l. All other array fasteners Structure shall be stainless steel or galvanized steel that provides the required mechanical strength.

Deputy Secretary (Tech:)  
Public Health Engg. Department  
Khyber Pakhtunkhwa

Engr. Ahsan Ali  
Public Health Engg. Department  
Khyber Pakhtunkhwa

ADLMEF

PD LA

KEV

PDA

KEV

KEV

SE(HH)

DIRECTOR  
Agr. Engineering  
Karnal, Peshawar

16/11/2019

**A - SPECIFICATIONS FOR SOLAR SYSTEMS-COMMON PART**

**1. SOLAR PANELS:**

- a. The PV module(s) shall contain mono crystalline silicon Grade-A Solar cells. (N-Type Mono PV Cell Modules and Bifacial Double Glass Modules due to its better performance will be given preference).
- b. The PV module should Work well with high-voltage input Inverters/ charge controllers (1000 Vdc).
- c. The PV Panel must have clear anodized aluminium frame with Anti-reflective, hydrophobic, low-iron Tempered cover glass.
- d. The Solar Modules shall meet the following valid IEC Standards or latest:
  - IEC 61215-1, IEC 61215-1-1, IEC 61215-2 :2016 (Design Qualification)
  - IEC61730-1:2016 (Safety - Requirements for construction)
  - IEC61730-2:2016 (Safety - Requirements for testing)
  - IEC TS-62804-1. (i.e: TUV PPP-58042 or Equivalent) Anti-PID Certification.
  - IEC 61701 Salt Mist Corrosion Resistance Test (Latest)
  - IEC 62716 Ammonia Corrosion Resistance Test (Latest)
  - IEC 60068-2-68 Sand and Dust Erosion Resistance Test.
- e. Unique Serial number, Name / Logo of manufacturer and separate date of manufacturing (DD/MM/YYYY) should be laminated inside the module so as to be clearly visible from the front side.
- f. A properly laminated sticker containing the following details should be available at the back side of the module.
  - Name of the manufacturer / distinctive logo.
  - Model Name and Type of Cell Technology.
  - Peak Watt Rating (Wp) and Power Tolerance Range
  - Voltage ( $V_{mp}$ ) and Current ( $I_{mp}$ ) at STC
  - Open Circuit Voltage (Voc) and Short Circuit Current (Isc)
  - Maximum System Voltage ( $V_{dc}$ ) (i.e: This should not be less than 1000 V<sub>dc</sub>)
  - Dimensions of PV Module
  - Test Standard(s) to which the module has been tested and certified.
- g. Following essential technical parameters of solar panel/modules should be provided with each panel supplied as well as in the technical proposal.
  - I-V curve for the solar photovoltaic module/panel.
  - Date and year of obtaining IEC PV module standardization qualification certificate.
  - Electrical Data (i.e: P<sub>max</sub>, Voc/V<sub>mp</sub>, Isc/I<sub>mp</sub> at nominal Cell Operating Temperature (NOCT).
  - PV Module efficiency at STC.
  - Working temperature range of PV Module.
- h. Each panel should have factory equipped weather proof terminal junction box having at least IP67 protection with provision of opening for replacement of DC cables, blocking diodes and easy debugging if necessary.
- i. Limited performance guarantee: panel power, in standard conditions, will not be less than 90% of nominal power by the end of 10 years of operation and at least 80% at the end of 25 years of operation with 25-year limited power warranty.
- j. The PV Module should have at least 10-years warranty for any defects and efficiency as mentioned above. It should be provided On Stamp Paper Signed and Sealed by Contractor at the time of Handing/Taking Over.
- k. The PV Module should have at-least 17.50 % Module efficiency with Positive Power Tolerance.

**DIRECTOR**  
Agnri: Engineering  
KPK Tarnab, Peshawar

*[Signature]*  
Executive Engineer  
Wazirak Canal Division  
Peshawar

Deputy Secretary (Tech:)  
Public Health Engg: Department  
Khyber Pakhtunkhwa

*[Signature]*  
AD (MCE)

*[Signature]*  
16/1/2019

*[Signature]*  
Jir-Jam

*[Signature]*  
Chairman  
Elect. Eng Dept  
16/01/2019  
PDA

Page 2 of 24

*[Signature]*  
XEN  
SECHD  
*[Signature]*  
XEN  
EEP



- l. The PV modules offered should not be more than 12 months old from the date of issue of work order.
- m. PV Module should have a Snow Load bearing of 5400 Pa and Wind Load Bearing of at least 2400 pa however if department deem appropriate may go for 3800 pa wind load depending upon their requirement.
- n. The Solar Module should be free from visual and cosmetics defects.
- o. The department/consultant on the expense of contractor/supplier shall verify Flash test reports with serial numbers from manufacturer for each panel (at the time of supply).
- p. All information regarding solar panel with above mentioned featured data should be accessible and verifiable online on the manufacturer website.
- q. IEC accredited lab test for solar panels is mandatory.
- r. EL (Electro-luminous) test will be performed randomly for each individual project at the cost of contractor/supplier.

**2. CABLE & WIRING:**

- a. The AC / DC cables should be made of 99.9% copper strands and Flexible.
- b. From PV Panel to Junction Box, XLPE or XLPO insulated & XLPE/PVC Sheathed, UV stabilized single core, Double Insulated. Stranded /flexible cables (Conforming preferably to EN 50618 or IEC FDIS 62930) be used.
- c. From JB to Inverter, the DC cable must have Single Core, double insulated and suitable for minimum 1000 V<sub>DC</sub> transmission.
- d. From Inverter to batteries, the DC cable can be single insulated, Single Core and suitable for minimum 300 V<sub>DC</sub> transmission.
- e. DC circuit breakers (not fuse) of  $\geq$  Voc of String Voltage and suitable ampere rating (1.25 to 1.50 Times of Rated Current of all strings connected) must be installed between PV modules and controller / inverter.
- f. AC Circuit Breaker (s) of suitable rating (1.25 to 1.50 Times of connected Load) must be installed between Controller / inverter to Load and Grid to Controller / Inverter.
- g. AC / DC breakers should be marked with the manufacturer model number, rated voltage, ampere rating and batch/serial number.
- h. DC / AC breakers rating should be approved from Engineer In-charge before installation at site.
- i. To prevent solar panels from damage an appropriate size of DC Breaker / Fuse should be installed for each PV string and Surge Protection should be installed for combined Array (before Main DC Breaker / Inverter).
- j. DC Breaker, AC Breaker & Change overs should be placed in an enclosure. All Enclosures / Junction boxes should be made from Hot Dipped Galvanized Sheets of minimum 16 SWG.
- k. Cables shall be clearly labelled with essential electrical parameters including manufacturer name, Voltage Range, standards etc.
- l. All DC Wiring shall be aesthetically neat and clean, over all wiring/connection losses shall not exceed 1% of the total rated output power.
- m. All connections/ socket outlet among array, controller, inverters, batteries, and pumping set etc must be made in junction boxes of adequate protection level.
- n. All wires/cables should be in standard flexible UV-Resistant conduits / HDPE of PN12, SDR 13.6, PE100 for outdoor installation & (2-3 feet deep) for underground wiring / Cabling and PVC ducts for indoor installation.
- o. The DC Combiner Junction Box should be properly earthed including earthing of door as well.
- p. The DC Combiner should contain proper bus bars of adequate size each for Positive, Negative and Earthing.

Deputy Secretary (Tech:)  
Public Health Engg. Department  
Faisalabad, Punjab

**DIRECTOR**  
Agril: Engineering  
PK Tarnab, Peshawar

ADCM&E

PO LG

16/01/2019

PDA

XEN

EEP

Copy of EEP  
16/01/2019

Exocutite Engg  
Wazir Khan  
Peshawar

Signature of Deputy Secretary

Signature of Jm

Signature of Jm

Signature of XEN

Signature of SEC HQ

- m. The PV modules will be mounted on metallic structures at the inner holes for cantilevered installation, which will evenly distribute the load of the panel around the support structure on both sides and in the middle.

**4. EARTHING/ GROUNDING:**

- a. The PV Panel frame and structure should be connected by the shortest practical route to an adequate earth contact (of Less than 5 Ohms Resistance) as per requirement of equipment manufacturer and site earth conditions, using an uninterrupted conductor. Grounding can reduce the risks of damage from lightning-induced surges.
- b. The Sizing of Earthing conductor will be done as per NEC Table 250.122
- c. The grounding conductor should be 99% Copper and PVC insulated / Bare Copper if installed underground along a defined path where size & Design shall be approved from Engineer In-charge before installation at site.
- d. Motor, inverter, Battery / Battery Box (if required), Main Distribution Board should be connected to an adequate earth contact / Grounding.
- e. Ground enhancement material (GEM) shall be used below and above the Earthing plate for proper grounding. Gravel or coarse sand shall be pour along with soil in the pit.
- f. Grounding / Earthing plate should be made of Copper plate of 4mm thickness & Size minimum 1.0 x 1.0 Ft.
- g. Grounding / Earthing conductor should be connected to the plate / Rode / GI Pipe by proper connector of minimum depth of 6 feet.
- h. Alternatively Earthing Rod of suitable size and length can be installed. (Instead of Plate). If given / mentioned in the BOQ/Design and Engineer In-Charge Approval.
- i. All nut / bolt and Earthing clamp shall be stainless steel or galvanized steel.

**5. BATTERIES:**

- a. The battery should be Deep Cycle, GEL, OPzV/OPzS, Lithium LiFePO4, Lead Carbon Type or equivalent. (Note: Battery type shall be specified in the bidding documents.)
- b. The battery must ensure safe and reliable operation in the whole range of ambient temperatures from -5° C to + 50° C.
- c. The maximum permissible self-discharge rate should not be more than 5 percent of rated capacity per month at 25° C.
- d. The battery shall have a certificate of compliances, issued by a recognized laboratory.
- e. The Batteries should have three years Comprehensive replacement warranty.
- f. The battery shall meet the requirements and recommendations given in IEC 61427, IEC 60896 1/22 (For VRLA) or equivalent. Lab Test Reports for battery cycle life should be provided.
- g. The Battery must support parallel connection to increase capacity in case of future expansion.
- h. Each Battery should have following minimum information printed on battery:
- Model Number, Serial Number and Type of battery.
  - Rated Voltage and Capacity (AH) at discharge rate of 10 Hours.
  - Origin of made.
  - Manufacturer Name with distinct logo.
- i. The following information must be provided in the data sheet while submitting technical bid.
- Certification/Test Standard(s) of the battery.
  - Information regarding cycles & self-discharge rate.
- j. In case of rechargeable battery bank (having more than one battery), the interconnection shall be made using lead plated copper bus bars or properly insulated flexible copper conductors.
- k. Battery disconnect switch / breaker of suitable size should be installed between batteries and inverter / charge controller.
- l. The Battery must have Low self-discharge rate, No memory effect and No gassing.

**DIRECTOR**  
Agril: Engineering  
KPK Tarnab, Peshawar  
16/01/2019

Engineer  
Public Division  
16/01/2019

Deputy Secretary (Tech:)  
Public Health Engg. Department  
Khyber Pakhtunkhwa

ADLM/45

PD LG

16/1/2019

XEN

PDA

XEN (AHE)

SE (HE)

K

EEP



and neat appearance. Battery Box /stand should be installed at a place in accordance with user's preference

**7. LED FLOOD LIGHTS:**

- a. Solar Based LEDs/Light fixtures shall conform to the latest IEC/ISO internationally recognized standards.
- b. LEDs/Light fixtures should not be Chip-on-board (COB) single chip type due to their poor heat dissipation.
- c. LEDs/Light fixtures shall be modular type with proper heat sinks.
- d. Solar based lights (LED fixtures etc) should provide at least 100 Lumen/watt.
- e. The Color rendering Index (CRI) must be equal or greater than 70
- f. LEDs/Light fixtures should be designed to deliver at least 10 years of service.
- g. Complete lightening unit shall be weather proof (Protection Class IP65).
- h. The output from the LEDs/Light fixtures should be constant throughout the duty cycle.

**8. AC ENERGY EFFICIENT LED LIGHT BULBS:**

Shape	Cap/Fitting/Base Type	Colour	Lumen Per Watt	Colour Temperature	Colour rendering index (CRI)	Life Time of Lamp (Hours)	Power Factor & Rated Voltage
Globe	E27	Cool or Warm White	Min 100W	2700K / 6500K	70	10,000	≥ 0.70 & 220 Vac

**Note:**

- LED Light Bulbs should be marked with the manufacturer model number, rated voltage, Wattage.

**9. AC ENERGY EFFICIENT CEILING FANS:**

Sweep		Rated Power	Speed		
Inches	MM	Watts	Rpm		
56	1400	50 Max	≥ 320		

- a. 10% + in Power Consumption is Allowed as per PSQCA Standard
- b. Rated Voltage: 230 V~ (±10V)
- c. Rated Frequency: 50 Hz
- d. Insulation Class: 155 (F) or better
- e. Motor Core: Electrical Steel Sheet
- f. Winding Wire: 99.99% Super Enamelled Copper CA Wire or 99.99% Pure Copper Wire.

**Note:**

- Energy efficient fan should be marked with the manufacturer model number, rated voltage, and wattage.

**10. DC ENERGY EFFICIENT LED LIGHT BULBS:**

- a. The LED lamps must have luminous efficacy of at least 80 lm/W (at 25 °C ambient temperature).
- b. The LED lamp must be protected against reversed polarity of the operation voltage.
- c. Base shall be an E-27 thread type.
- d. The emitted light shall be cool or warm white.

Deputy Secretary (Tech.)  
Public Health Engg. Department  
Khyber Pakhtunkhwa

DIRECTOR  
Agril. Engineering  
Peshawar  
16/01/2017  
Executive Engineer  
Environment  
Muzaffargarh

[Signatures and stamps]  
 Jai. Jem.  
 XEN  
 PDA  
 SE(MR)  
 XEN  
 PDA  
 XEN  
 E/P



**5.1 GEL BATTERIES:**

- 5.1.1 Cycle life of the GEL battery (12V) before 80% capacity of Initial Capacity must be minimum **1000** cycles @ 50% depth of discharge (DOD) at discharge rate of 10 Hours
- 5.1.2 Cycle life of the GEL battery (2V Cell) before 80% capacity of Initial Capacity must be minimum **1300** cycles @ 50% depth of discharge (DOD) at discharge rate of 10 Hours

**5.2 LEAD CARBON:**

- 5.2.1 Cycle life of the Lead Carbon battery (12V) before 80% capacity of Initial Capacity must be minimum **2000** cycles @ 50% depth of discharge (DOD) at discharge rate of 10 Hours.
- 5.2.2 Cycle life of the Lead Carbon battery (2V) before 80% capacity of Initial Capacity must be minimum **2500** cycles @ 50% depth of discharge (DOD) at discharge rate of 10 Hours.

**5.3 OPzV / OPzS BATTERIES:**

- 5.3.1 Cycle life of the OPzV / OPzS battery (12V) before 80% capacity of Initial Capacity must be minimum **2000** cycles @ 50% depth of discharge (DOD) at discharge rate of 10 Hours
- 5.3.2 Cycle life of the OPzV / OPzS battery (2V Cell) before 80% capacity of Initial Capacity must be minimum **2500** cycles @ 50% depth of discharge (DOD) at discharge rate of 10 Hours

**5.4 LITHIUM BATTERIES (LiFePO4):**

- 5.4.1 Cycle life of the Lithium LiFePO4 battery before 80% capacity of Initial Capacity must be minimum **5750** cycles @ 50% depth of discharge (DOD) at discharge rate of 10 Hours.
- 5.4.2 The battery must have Integrated Battery Management System (BMS) to ensure battery safety and reliability.
- 5.4.3 The BMS of the battery must have the following specifications:
  - Temperature protection
  - Over charge protection
  - Low voltage disconnect
  - High Voltage Disconnect
  - Short circuit alarm function
  - Self-balancing function
- 5.4.4 The LiFePO4 Battery must have LED status and alarm indication.
- 5.4.5 The charge and discharge rate of the battery must be designed at 0.2C minimum but capable of handling 0.5C charge and discharge currents.

**Note:**

- **Product brochure, catalogue and certificates must be attached with the Technical Bid.**

**6. BOX / STAND FOR BATTERIES, SHS-INVERTER & CHARGE CONTROLLER:**

- a. The batteries should be housed in a vented compartment/stand that prevents users from coming in contact with battery terminals. This compartment/stand should be strong enough to accommodate the weight of the battery.
- b. A mechanism to prevent opening and entry of the battery should be provided.
- c. This compartment should be manufactured of mild steel of at least **18 SWG**.
- d. The compartment should be powder coated paint.
- e. The entire enclosure/stand must be constructed to last at least twenty years without maintenance and should be protected against corrosion. The enclosure should have a clean

Deputy Secretary (Tech.)  
Public Health Engg. Department  
Khyber Pakhtunkhwa

ADLMEE

Jas. Jom

16/01/2019

XEN

PD LG

SEH

PDA

XEN

ELP

- e. The wide angle shall be between 120° to 125°.
- f. Operating Voltage 12Vdc / 24Vdc
- g. Lamps should be marked with the manufacturer model number, rated voltage, wattage and date of manufacture or batch number.

**11. DC CEILING FANS:**

Sweep	Rated Power	Speed	Service Value	Operating Voltage
Inches	Watts	Rpm	Air Delivery/W	V
48 ((with Speed Control) Metal Blades	30-36	> =320 RPM	9.54	12 / 24

**12. DC PEDISTAL FANS:**

Sweep	Rated Power	Speed	Service Value	Operating Voltage
Inches	Watts	Rpm	Air Delivery/W	V
18 Inch (with Speed Control)	18-30 W	1250 RPM (Full Speed)	5.22	12 / 24

**13. INVERTER BASED SPLIT AC**

Inverter based AC with both heating and cooling option.

S.No	DESCRIPTION	UNIT	DETAILS
1	Compressor	Type	Multistage Rotary
2	Noise Level (Indoor)	Db (Max)	≤ 50
3	Voltage Range	Volts (Min & Max)	180 to 250 Vac

**14. PVC CHANNEL DUCTS & PIPES**

a. A product of good quality standard material standardized by the provincial standardization committee with suitable size to be provided / used, as per direction/approval of Engineer In-charge.

- b. Ducting must be done with proper steel nails and clips.
- c. All ducting (wiring) must be align.

**15. FLEXIBLE PVC PIPE**

a. The flexible PVC pipe should be of good quality material standardized by the provincial standardization committee with suitable size to be provided / used, as per direction/approval of Engineer In-charge.

**16. CIVIL WORK:**

The following Civil Works should be carried out for ground installation of SPV Modules/mounting structures.

- a. Minor Cutting and clearing of trees/plantation to avoid shadows.
- b. Civil work for earthing system as per the statutory requirements.

**17. REFLECTIVE / INSULATING PAINT**

The Roof Paint should be ultra-white, high reflective, 100% acrylic elastomeric roof sealer designed for fixing leaks in roofs the paint should contain heat reflective pigments and additives that provide an excellent, highly protective barrier which reflects the sun's heat and destructive UV rays leaves a brilliant ultra-white finish, reducing surface heat absorption up 20°F.

Deputy Secretary (Tech.)  
Public Health Engg. Department  
Khyber Pakhtunkhwa

DIRECTOR  
Agril. Engineering  
KPK Tamab, Peshawar

16/01/2017

Executive Engineer  
Warak, Peshawar

Jani-Zen

16/01/2017

DEN

PO. LG

XEN

SE(HR)

ADLMER

K



The Reflective paint should comply with ASTM D6083, Fiber Reinforced for more protection, strength and durability which allows for contraction and expansion, Resists surface fungal growth.

**18. WARRANTY/AFTER SALE SERVICE:**

Three years Comprehensive Free Replacement, Repair and maintenance Warranty at site (Free of Cost) should be provided for all the components of Solar System. (if not mentioned separately otherwise)

STANDARDIZATION COMMITTEE GOVERNMENT OF KP

Deputy Secretary (Tech:)  
Public Health Engg. Department  
Khyber Pakhtunkhwa

Executive Engineer  
Worsak Chams Division  
Peshawar

~~DIRECTOR~~  
Agril: Engineering  
KPK Tarnab, Peshawar

M. Khan  
SE (HE)

CCM

Shi-Jam -

16/01/2019

16/01/2019

MR  
AEN

PDA

Khan

XEN

Khan  
ELP

## B - SPECIFICATIONS FOR SOLAR PUMPING SYSTEMS

### 19. PUMP (SUBERSIBLE):

Pump should be supplied having standard ISO-9906 specifications. The pump must be submersible, made of stainless steel. The characteristic curves (Original from Manufacturer) showing the efficiency at duty point and performance of the pump should be provided in the technical proposal and also at the time of pre-supply testing. The quoted pump should be tested for its performance and certified as per ISO-9906 standard. The pump should be suitable for installation and operation in tube wells/dug wells/open well with clear water discharge. Pump shall comprise of bowl assembly and non-return valve as integral part of pump's parts. Pump and motor shall rigidly couple through NEMA standard coupling. The stage casings of pumps should be connected as per NEMA/ANSI/AWWA /ASTM/BSS standard. Each stage casing must have replaceable wear ring. The impellers shall be secured to the pump shaft with tapered conical sleeves pressed into the taper bore of impeller or impeller secured through chrome plated stainless steel hexagonal sleeves. Suction casing must be between pump and motor with suction strainer as protection of pump against coarse impurities of the liquid handled.

#### Specification for main components of the Pumps:

S.NO	Components	Specifications
1	Casing/Diffuser	The Casing/Diffuser should be in fabricated stainless steel AISI 304 / 316.
2	Impellers	Stainless steel AISI 304 / 316.
3	Driving Shaft	Stainless steel 304/420 / 316
4	Sleeves	Stainless steel AISI 329/ 304 / 316
5	Gaskets	Rubber Gaskets
6	Bearings	AISI 329 stainless steel
7	Coupling & Screen + Cable Guard	Stainless steel AISI 316/319/304/420
8	Non-Return Valve / Sluice Valve	As per British standard specifications (BSS), Minimum PN16 (16 Bar) or Above (As Per Site Requirements) PN Value / Bar Capacity of Valves must be more than Installed Pump Max/Shut-off Head Minus Static Water Level of Bore. (Leakages in Valves are NOT Acceptable).
9	Pressure Gauge	As per British standard specifications (BSS), having PSI or Bar scale (4 Inch Size), Liquid Filled, minimum 350 PSI Range, Looped Siphon tube Pipe, Stainless Steel/polypropylene Casing.
10	Clamps	Steel – Pressed
11	Pump Efficiency	<b>Minimum efficiency of the pump (For discharge of 3000 GPH and more) should be 70% ensured at duty point. (Duty Point of the Pump be preferably selected at the peak efficiency point or (Within ±10% of discharge) of Pump Peak efficiency Point)</b>

### 20. MOTOR:

The winding material should be 99.99% copper. The motor should have wet type, water cool rewind-able/repairable stator. The motor should have non-disposable/non-hermetically sealed winding. The insulation class of the winding material should be mentioned. For each model quoted, all the technical parameters such as rated voltage, power factor, efficiency, full load ampere, speed

DIRECTOR  
Agril: Engineering  
& Tarnab, Peshawar

Executive Engineer  
Wazir Khan, Dera Ismail Khan  
Punjab

Deputy Secretary (Tech:)  
Public Health Engg. Department  
Khyber Pakhtunkhwa

Page 10 of 24

16/01/2015

16/01/2015

16/01/2015

PDA

16/01/2015

16/01/2015

16/01/2015

16/01/2015



and other similar parameters should be provided at the time of pre-supply testing. The testing report with all basic parameters should also be provided at the time of pre-supply testing.

The motor shall be manufactured in compliance with National Electrical Manufacturer Association (NEMA) standards. The motor shall be three-phase submersible and shall be capable of operating at rated voltage of 380 Volts at 50 Hz. The motor should be capable of operating with variable speed through V/F control. Winding of the motor shall of rewind able type with class – IC40 insulation and IP68 protection. The synchronous speed should be 2850-2950 RPM. Motor shall be capable of operating in well water with temperature normally start from 40°C. Motor should be designed for continuous operation. Motor must be filled with water without any chemical additives hazards to health for cooling. The motor must be properly protected against the entry of well water sand etc by double mechanical seal one is rotating and other stationary and must be made of Silicon carbide/ Tungsten carbide and must be protected with sand protection guards. All supports shall be high grade cast iron and stator outer side jacket body should be in stainless steel in AISI 304. The excessive pressure due to heating up of the filled water must be compensated by a pressure equalizing rubber diaphragm in the lower part of the motor. The axial thrust of the pump shall be countered by oscillating sliding block type thrust bearing. The thrust bearing of the motor should be able to bear a download thrust force from the water pump and the upward thrust force produced while starting the water pump. Motor in open well / water tank should be installed with cooling jacket / shroud / sleeve and when motor is installed in bore then installing of cooling jacket is also required. Motor shall be capable of maximum of 20 starts in an hour. Motor efficiency of motors 7.5 HP and above should not be less than 75% at Full Load and Motor Rated Voltage.

**Technical specification of rewind-able wet stators, three phase squirrel cage water filled submersible motor.**

S.No	Components	Specification
1.	Winding	Made of pure electrolyte copper and the winding insulation should be suitable for > 1000 Volts and must full fill resistant tests range.
2.	Stator	Energy efficient low-losses electrical magnetic sheet should be fixed in stainless steel casing. M800 or M600 magnetic sheet are preferable to use.
3.	Rotor	Energy efficient low-losses electrical magnetic sheet fixed with high grade copper bars. M800 or M600 magnetic sheets are preferable to use.
4.	Spline Shaft	AISI 420 stainless steel, flange dimension according to NEMA standard, over size design to ensure stiffness in severs condition.
5.	Shaft bearing	Water lubricated guide/general bearings fixed in upper and lower brackets should be made of metal impregnated carbon.
6.	Lower thrust bearing	Thrust sliding block bearings, self-aligning Mitchell type, should be able withstand <b>20000N</b> axial load
7.	Mechanical Seal (Stationary & Rotary)	Silicon carbide or tungsten carbide mechanical seal.
8.	Cooling filling fluid	Water mixed with non-toxic anti-freeze provide cooling and lubrication also protect and prevent inside parts from corrosion
	Degree of protection	IP68
	Insulation Class	Insulation Class B (130°C) NEMA Insulation Class F (155°C) NEMA or above Will be given

Ex. Engr. Engineer  
Muzakir Chishti Division  
Punjab

**DIRECTOR**  
Agril: Engineering  
K. M. Tamab, Peshawar

Deputy Secretary (Tech.)  
Public Health Engg. Department  
Khyber Pakhtunkhwa

Abi-Zam. (16/01/2019)

AM  
AER

M. H. D  
SE (HE)

U. R.

Samir

16/01/2019

PDA

XEN

ESP

		Preference.
11.	Voltage Tolerance	+6% to -10%
12.	Mounting position	Capable of both Vertical or horizontal Installation
13.	Class	IC40
14.	Maximum Immersion	150 Meters
15.	Starting per hour	20

**21. SUBMERSIBLE FLATE ELECTRIC CABLE (4-Core):**

The Submersible cable (4-Core) should be made of 99.9% copper strands with double PVC insulation for **1000Vac**, should be adequately flexible and environment friendly. Stranded and flexible insulated copper wires and cables must be used for all outdoor and indoor installations. The wiring that leads into the building shall be protected in a conduit. The cable must have undergone quality tests as per BSS standards. Cable size should be selected so that the Voltage drop Losses in the drop cable should not be more than 2.5%.

Following lab tests are mandatory.

- Conductor resistance test.
- Insulation resistance test.
- Pressure test.
- Spark test.
- Note: The Supplier should provide the quality tests certificates at the time of pre-supply testing and inspection.

**22. COLUMN PIPE:**

The column pipe shall be flanged ERW steel pipes confirming to ASTM designation A-53 with a minimum thickness of **3.6 / 4.0 mm (3.6 mm for pipes upto 2.5" dia and 4 mm for pipes above 2.5" dia)** and shall be painted with corrosion resistance paint of suitable thickness. Flanges thickness of 19-20 mm shall have grooves for cable passage. Each column pipe shall be complete with gaskets, bolts/studs, washers and nuts. All nuts, bolts, and washers shall be made of minimum A2 grade stainless steel.

The column pipe shall be supplied in interchangeable section having an approximate length of 10 feet column pipe shall be flanged perpendicular to the axis of pipe.

Column pipe size should be selected so that the Head Losses in the column pipe should not be more than 5%.

For Reference a table-1 is given below.

HDPE Pipe of  $\geq 0.75$  Inch diameter, SDR 13.6, PE100, conforming to ASTM F-2160 Standard without Joints to be installed/included along with and equal to Column pipe for confirming Water Level testing purpose.

**FEATURES:**

- Manufacturer's pipes should meet international standards like BSEN 10255 & ASTM A 53.
- Dimensional accuracy circularity and plan end cut should be observed,
- Weld strength of pipe and mechanical properties or raw material should be tested as per manufacturing standards.
- Pipes should be NDT tested (Non-destructive – Eddy current)
- Pipes should be hydrostatically pressure as per manufacturing standard.
- Pipes should be gone through straightening process to remove bendiness.

**DIRECTOR**  
Agril: Engineering  
Tarnab, Peshawar

Executive Engineer  
Water Supply Division  
Peshawar

Deputy Secretary (Tech:)  
Public Health Engg: Department  
Khyber Pakhtunkhwa

Handwritten signatures and dates including: 11/11/2017, 16/01/2019, 16/01/2017, and various initials like 'Jama', 'SE (HR)', 'K', 'XEm', 'PDA', 'ZUC', 'Kamran', 'DE-4', 'Jama'.



**23. TOPSET:**

Top set shall comprise of Bore covers plate, (covering bore hole completely and securely), installation/suspension clamps (2-Nos), sluice valve (BSS/ASTM), reflex valve (BSS/ASTM), Washout Valve approx. 3-4 feet above the ground (T-Connection For Testing Pump's discharge), connector and cable jointing material (Cable connection from motor to switching device shall be joint free), Liquid Filled Pressure gauge minimum 4 Inch diameter suitable / appropriate for the required head pressure and cable ties. Bore Cover Plate should have provision for water level testing facility (i.e: Hole for Sonic Water Level Meter / HDPE Pipe insertion)

For Cleaning of solar Panels, Plastic pressure pipe should be provided of suitable length to reach the furthest / last Solar Panel.

Every Water Supply Scheme should have a non-removable name plate fitted at suitable place / box having essential information and bearing the name of supplier, Consultant and client.

**24. SOLAR PUMP INVERTER / CONTROLLER:**

- a. The solar pump inverter/controller should have built-in advance version of Auto MPPT controller, over load protection, Soft start/Soft Stop Features and Variable Frequency Drive (VFD) with integrated Gate Bipolar Transistors (IGBTs) of European, USA or Japanese origin or atleast equivalent.
- b. The make and origin of the inverter/controller should be clearly mentioned in the catalog and submitted in the technical proposal.
- c. The inverter offered should comply to or Equivalent standards:
  - i. CE/RoHS
  - ii. Low Voltage Directive 2014/35/EU
  - iii. EMC Directive 2014/30/EU
  - iv. IEC 62109-1 (Safety of Power Converters for use in PV Systems)
- d. The complete datasheet showing all the electrical parameters like input & output voltage ranges should be provided in the technical bid.
- e. All the electrical parameters like input & output voltage ranges, and efficiency should be provided at the time of pre-supply testing and inspection.
- f. Efficiency of inverter should be 96% and above at Rated Capacity.
- g. Efficiency of MPPT should be 98% and above.
- h. The inverter < 25kW ingress protection of inverter must be minimum IP 65 Rating or above and for inverter ≥ 25kW ingress protection of inverter / enclosure will be minimum IP 54 Rating or above.
- i. Inverter / Controller having the capability to run both on AC and DC Power would be given preference.
- j. Inverter should have at least three (3) years product and performance warranty.
- k. The Pump Controller/Inverter should have an ON/OFF Switch/Button to Start and Stop the Pump.
- l. Inverter should have active RS232/485 etc communication port available, the Data available through this port can be used for Remote Monitoring.

Inverter circuit must include protection against:

- i. Over or Low voltages and currents beyond critical level of the inverters circuits.
- ii. Protection against accidental short circuits & reverse polarity connections.
- iii. Protection against lightning induced transients.
- iv. Over load protection.
- v. Low RPM Protection (i.e: Frequency < 30 Hz or as per pump characteristic curve) Motor Should Stop.
- vi. Dry run protection. (PF / Current Based).

**DIRECTOR**  
Agril: Engineering  
Tarnab, Peshawar

Executive Engineer  
Water & Power  
Tarnab, Peshawar

Deputy Secretary (Techn.)  
Public Health Engg: Department  
Khyber Pakhtunkhwa

Abi-Zen (16/01/2019)

CC

Amir

16/01/2019

PDA

16/01/2019

16/01/2019

SEC (HD)

**25. dV/dT or Sine Filters With Inverter (VFD):**

- a. The use of load reactors increases the reliability, performance, and efficiency of VFD systems, extends the life of both drives and motors, and reduces the amount of energy consumed by the motor/drive system.
- b. Output dV/dT or Sine Filters (between VFD and Motor) of appropriate size (for 3-phase  $\geq 380\text{Vac}$  Motor of Class B Insulation) should be used where the cable length between motor and inverter is more than Fifty (50) Feet or as advised / recommended by the inverter manufacturer in their Technical Documentation. For Cable lengths of more than 150 meters sine filters should be used.
- c. Filter should be enclosed in a vented box.
- d. Filter Efficiency should be minimum 97%.
- e. Filter should have a current rating of equal or greater than Motor FLA Rated Current.
- f. Distance between filter and pumping inverter should not be more than 2 meters.
- g. Motors with Insulation Class F, H or above are exempted from the requirement of dV/dT Filter.

**26. SYSTEM DESIGN FOR PUMPING SYSTEM:**

- a. Suitable factor of safety should be applied while designing the system in order to have compensations for variations in irradiations.
- b. For Fix Structure and Auto Tracker, the PV panel **peak power at STC (Wp) should be 75% more** than the Motor basic input power (**PV Loss Compensation Factor = 1.75**).
- c. For Auto /Manual Tracker, the PV panel **peak power at STC (Wp) should be 50% more** than the Motor basic input power (**PV Loss Compensation Factor = 1.5**) as per direction of Engineer Incharge
- d. If Single Axis Auto Tracker Structure is installed on the above factor, then daily operational timings of pumping can be increased by 10-20%, as compared to fixed structure installation.

e. Total PV Power (Wp) (Imperial Gallons) =  $\frac{Q \text{ (IGPH)} * \text{TDH (ft)} * 746 * \text{PV Loss Factor}}{60 * 3300 * \eta_{\text{pump}} * \eta_{\text{motor}}}$

f. Total PV Power (Wp) (US-Gallons) =  $\frac{Q \text{ (US-GPH)} * \text{TDH (ft)} * 746 * \text{PV Loss Factor}}{60 * 3960 * \eta_{\text{pump}} * \eta_{\text{motor}}}$

g. Total PV Power (Wp) (Metric Units) =  $\frac{Q \text{ (m}^3\text{/hr)} * \text{TDH (m)} * 9.81 * 1000 * \text{PV Loss Factor}}{3600 * \eta_{\text{pump}} * \eta_{\text{motor}}}$

- h. Voltage ( $V_{mp}$ ) of Each String of PV Panels should be as per details given below and String Voltage ( $V_{mp}$ ) should be within the MPPT range of Inverter.

For 380 Vac 3-Phase Motor =  $380 * 1.414 * 1.06 = 570 \text{ Vdc}$  String, minimum

For 220 Vac 3-Phase Motor =  $220 * 1.414 = 310 \text{ Vdc}$  String.

- iii. Small Inverters (i.e: 3-Phase, 220 Vac) with voltage boost function are exempted from the above string voltage requirements. String can made as per boost Inverter Controller recommended String DC Voltage and should not be less than 230Vdc in any case.

- i. Details of each PV Panel string should be submitted in Technical proposal (i.e: Nos of total strings and Nos of PV panels in each string along with wattage and  $V_{mp}$  of each PV panel).

Unjustified Oversizing in PV Panels Wattage is not allowed.

To avoid any oversizing, all commercially available PV Panels should be considered.

Deputy Secretary (Tech:)  
Public Health Engg: Department  
Khyber Pakhtunkhwa

bi-jun (16/01/2019)

CC

Samuel

16/01/2019

PDA

SE (HE)

XEN



- l. Solar Pump Inverter should have a kW capacity equal or greater than the Motor Rated Input Power.
- m. Solar Pump Inverter / Controller Size (kW)  $\geq$  (Motor Rated Power in kW / Motor Efficiency).
- n. Solar Pump Inverter / Controller should have a current rating of 1.15 Times (minimum) of Motor FLA Rated Current.
- o. Motor should not be loaded more than 90%. (i.e: Design / Calculated BHP should not be more than 90% of Motor Rated Horse Power)
- p. Along with this specification, contractors should also follow manufacturer's recommendations for all major components of Solar Pumping System.
- q. Requirement of Efficiency for Motor i.e. 75% will not apply on Motors smaller than or equal to 5.5HP and the requirement of efficiency for pump i.e. 70% will not apply on pumps having discharge equal to or lower than 3000 GPH.

**27. PRESSURE PUMPS (UPTO 5.5 HP):**

- a. Submersible pump confirming to ISO-9906 Standard.
- b. Pump + AC Motor (3-Phase-220V/380V) or DC Motor and Pump with Display Unit.
- c. Solar pump inverter/controller should be MPPT based and Minimum Ingress Protection of IP65.
- d. In case, where the column pipe diameter is less than or equal to 1.5-inch (For discharge equal or less than 6000 LPH and/or for Motor 4 HP and below), HDPE pipe of at least PN12 / SDR 13.6 / PE100 (For TDH of equal or less than 300 ft) without joint may be used instead of MS pipe for better economics and to avoid hydraulic losses. However stainless steel rope of minimum diameter of 6 mm (28 mm<sup>2</sup>) for suspension of pump-set must be supplied with HDPE pipe. (Note: For TDH of more than 300 ft, HDPE Pipe type / thickness may be increased/changed accordingly)
- e. Top set shall comprise of Suitable Galvanized stand (Design should be verified from Engineer In-Charge before start of work)
- f. For Pressure Pumps  $\leq$  5.5 HP schemes, Solar Module efficiency requirement is minimum 16%. (Only for Cut Cells PV Modules or Cell Size of 5 Inches PV Modules).
- g. Connection to overhead water storage tank. Top bend, S.S Fasteners & Erection clamps.
- h. Civil work to protect borehole i/e foundation.
- i. The pump should operate safely with Sand particles up to (50) gram/m<sup>3</sup>.

**28. DC SOLAR WATER PUMP-SETS (UPTO 5.5 HP)**

- a. DC Motor can also be provided for Equal or less than 5.5 HP.
- b. Motor should be capable of both AC and DC operation. There must be auto power source recognition feature.
- c. The motor should be brushless, permanent magnet type.
- d. The Controller must have a display Unit, showing all essential parameters (i.e: Current, Voltage etc).
- e. The Controller must be of MPPT type. MPPT efficiency should be equal or more than 98%
- f. Pump should have auto and soft start / stop feature.
- g. The pump-set should have following protections
  1. Dry Running Protection
  2. Reverse Polarity Protection
  3. Over phase protection
  4. Over Head Protection
  5. Lose Phase Protection
  6. Electronic Protection
  7. Over Current/ Overload Protection

**DIRECTOR**  
Agril: Engineering  
KPK Tarnab, Peshawar

Executive Engineer  
Water Supply Division  
KPK Tarnab, Peshawar

Deputy Secretary (Tech:)  
Public Health Engg: Department  
Khyber Pakhtunkhwa

Signature: [Handwritten] 16/01/2019

Signature: [Handwritten] 16/01/2019

Signature: [Handwritten]

Signature: [Handwritten]

Signature: [Handwritten] 16/01/2019

Signature: [Handwritten]

Signature: [Handwritten]

Signature: [Handwritten]

**29. SOLAR AUTO TRACKER:**

- a. The solar tracker offered should be fully automatic and intelligent, and must be capable of Single axis tracking (from east to West) and should have its own power supply (PV Panel, Battery and Charge Controllers) other than PV Panel used for Pumping Setup.
- b. Individual Auto-Tracker should be  $\geq 4$  kW each and Tracking Accuracy should be within  $\pm 5^\circ$ .
- c. The auto Tracker should also have manual control mode to adjust the tracking angle manually. Structure Material Should be Hot Dipped Galvanized Steel (Minimum 80 Microns).
- d. All nuts, bolts, washers and other fasteners for mounting structure shall be made of minimum A2 grade stainless steel.
- e. Foundation and other details will be separately provided.
- f. Three years Comprehensive Free Replacement, Repair and maintenance Warranty (Free of Cost) should be provided for all the components of auto Tracker (including Batteries).

**30. PV MOUNTING FRAME WITH MANUAL TRAKERING :**

Suitable for 2.5 or 3.5 KW PV Panels easily movable in multi directions having flanges with bearing balls  $\frac{1}{2}$ " and having angle adjustment. Base steel cage  $\frac{3}{4}$ ", MS rod 3.5 feet length with nut-bolts system for strong anchoring. Pillar pipe 6 mm with 5.5" dia, base plate 15"x15"x1/2" size with 04 numbers of supports. Support for PV, 5 mm thickness 4" dia pipe and 24"x12"x 1/4" side plates. MS Angle side bracing 2"x 2" x  $\frac{1}{4}$ ". MS Angle frame 2"x 2" x  $\frac{1}{4}$ " for panel mounting. Steel structures/frames shall be powder coated. Galvanized nuts, bolts and washers for tracker fitting. Steel frame shall be properly designed and shall withstand wind speed/load of at least 130 km/hr and tough weather condition.

**31. PRE-SUPPLY TESTING & INSPECTION:**

The firm applying for the tender has to provide the recent test bed reports from the pump/motor manufacturer or any other third party as per ISO-9906 standard. Each of the offered pump set models must undergo these test prior to supply and installation, In order to ensure the quality and standard of the equipment contractor may be asked to provide test result conducted by third party for re-verification.

**32. OPERATION AND MAINTENANCE MANUAL:**

An Operation and Maintenance Manual, in English and Urdu language, should be prepared and provided by the contractor with the solar PV pumping system. The Manual should have information about solar energy, photovoltaic, modules, DC/AC motor pump set, tracking system (if any), mounting structures, electronics and switches. It should also have clear instructions about mounting of PV module, DO's and DONT's and on regular maintenance and Trouble Shooting of the pumping system. Name and address of the person or Centre to be contacted in case of failure or complaint should also be provided.

STANDARDIZATION COMMISSION K.P.

*[Handwritten signatures and stamps]*

**DIRECTOR**  
Agril: Engineering  
L.P.K Tamab, Peshawar

Executive Engineer  
Water & Power  
Peshawar

Page 16 of 24

Deputy Secretary (Tech:)  
Public Health Engg: Department  
Khyber Pakhtunkhwa

*[Handwritten notes and dates]*  
16/01/2019  
16/01/2019  
16/01/2019

*[Handwritten initials and signatures]*  
SE(HA)  
SEJ  
K. ELP



**C- SPECIFICATIONS FOR SOLAR HOMES & BUILDING SYSTEMS.**

**33. GRID TIE INVERTER (ON-Grid without battery backup / Hybrid with battery backup)**

1. UL-1741 Certified or IEC 62109-1 and IEC 62109-2 or Equivalent Certificates.
2. Minimum 95% Conversion Efficiency at Rated Capacity (High Frequency Inverters).
3. Minimum 87% Efficiency for Transformer based inverters (Low frequency Inverters).
4. The inverter should have built-in MPPT controller
5. The Priority of the inverter should be set that load will be running from the solar energy then Grid and in the end will be running from the Battery Backup.
6. Inverter (Hybrid Only) must be capable of configuring for Charging GEL, Lead Carbon, OPzV/OPzS Batteries and Lithium Iron Phosphate batteries (LiFePO4).
7. Hybrid Inverter (If Quoted along with Lithium Batteries) must be capable of communication with the BMS of Lithium Batteries.
8. Rated output voltage of inverter / Controller shall be pure sine wave AC.
9. Total harmonic distortion (THD) in AC output should not exceed 3% at rated capacity.
10. The degree of protection of the ON-Grid inverter Installation should be IP-65 rated and for indoor Hybrid Inverter installation, the IP rating should be IP-20 or above.
11. Wide input voltage range capability. (i.e: Voltage Range can be adjustable / selectable)
12. Natural convection cooling for maximum reliability
13. Outdoor enclosure for unrestricted use under any environmental conditions
14. Capability to connect external sensors for monitoring environmental conditions.
15. The output of the inverter must synchronize automatically its AC output to the exact AC voltage and frequency of the grid.
16. The Inverter should have the capability of Parallel operation upto three units. (Only For projects, where more than one inverter should be installed).
17. Inverter should have active RS232/485 etc communication port, the Data available through this port can be used for Remote Monitoring.
18. Liquid crystal display should at least be provided on the inverters front panel or on separate data logging/display device to display following
  - a. DC Input Voltage
  - b. DC Input current
  - c. AC Power output (kW)
  - d. Current time and date
  - e. Temperatures (C)
  - f. Converter status
19. Inverter circuit must include protection against:
  - Over or Low voltages and currents beyond critical level of the inverters circuits.
  - Protection against accidental short circuits.
  - Protection against lightning induced transients.
  - Over load protection.

**34. OFF-GRID / HYBRID INVERTER:**

1. The Inverter must be pure sine wave output suitable for 220 Volt, 50 Hz.
2. Inverter must be capable of configuring for Charging GEL, Lead Carbon, OPzV/OPzS Batteries and Lithium Iron Phosphate batteries (LiFePO4).
3. The Inverter / system must have a MPPT Solar Charge Controller.
4. Minimum 92% Conversion Efficiency at Rated Capacity (High Frequency Inverters).
5. Minimum 87% Efficiency for Transformer based inverters (Low frequency Inverters).
6. Total harmonic distortion (THD) in AC output should not exceed 3% at rated capacity.

**DIRECTOR**  
Civil: Engineering  
Tarnab, Peshawar

Executive Engineer  
Wastewater Division

Deputy Secretary (Tech.)  
Public Health Engg: Department  
Khyber Pakhtunkhwa

Handwritten signatures and dates: 11/11/2019, 16/01/2019, 16/01/2019, and various initials including XEN, SETHA, and EEP.

7. The inverter must be user programmable for selecting PV, Grid and Battery Priority as well as Built-in programmed and user defined voltage and current settings of the charge controller for GEL, Lead Carbon, OPzV/OPzS batteries and Lithium Iron Phosphate batteries (LiFePO4).
8. The Inverter must have Protective function limits for:
  - a. AC under voltage protection
  - b. AC over voltage protection
  - c. Battery under voltage Alarm
  - d. Low Voltage Disconnect
  - e. High Voltage Disconnect
  - f. Overload and Short Circuit Protection
  - g. Over Temperature Protection
9. The inverter must be ISO 9001, ISO 14001 and CE Certified.
10. The inverter must have IEC 62109-1 and IEC 62109-2, or Equivalent Certificates.
11. The degree of protection of the outdoor inverter Installation should be IP-55 rated and for indoor Inverter installation, the IP rating should be IP-20 or above.
12. Wide input voltage range capability.
13. Inverter should have active RS232/485 etc communication port, the Data available through this port can be used for Remote Monitoring.
14. Inverter (If Quoted along with Lithium Batteries) must be capable of communication with the BMS of Lithium Batteries.

**Note:**

- Product Brochure, Catalog and certificates must be attached with the Technical Bid.

STANDARDIZATION COMMITTEE GOVERNMENT OF KP

*[Signature]*  
11/11/2019

Deputy Secretary (Technical)  
Public Health Engineering Division  
(Khyber Pakhtunkhwa)

*[Signature]*  
**DIRECTOR**  
Agril: Engineering  
PK Tamab, Peshawar

*[Signature]*  
Executive Engineer  
Water & Sewerage Division  
Peshawar

*[Signature]* 16/01/2019

*[Signature]*  
XEN

*[Signature]*

*[Signature]*  
SE HA

*[Signature]*

*[Signature]*

*[Signature]* 16/01/2019

*[Signature]*  
PDA

*[Signature]*  
XEN

*[Signature]*  
ERP



## D - SPECIFICATIONS FOR SOLAR STREET LIGHTS

### **35. SOLAR STREET / ROAD LIGHT SYSTEM DESIGN:**

- a. Assessment of Wattage of the LED Luminaire, Pole Height, Pole thickness, Pole top diameter, Pole base diameter, Base plate size, Base Plate thickness, Stiffener size, Stiffener thickness, Pole arm design, Pole Arm Length, Pole arm thickness, Pole arm diameter, Pole arm Placement / Fixing position, RCC foundation size, Anchor / J-bolt size, Steel Rebars cage (Mesh) and Number of Poles (Pole to Pole distance) should be according to the design provided / approved by the Engineer In-charge.
- b. Round Conical or Octagonal Hot Dipped Galvanized Pole of average 80 Microns should be installed.
- c. All Nuts, Bolts and Washers should be stainless steel.
- d. Pole base plate should be tightened in between two stainless steel nuts and washers (one nut and washer at upper and one nut and washer at lower side of the base plate).
- e. All Anchor / J-bolt shall be in level and align to each other.
- f. All Anchor / J-bolt shall be galvanized.
- g. All Anchor / J-bolt shall have at least 150 mm minimum threads.
- h. All poles shall be installed on levelling nuts secured to the anchor bolts and with locking nuts on the top of the base flange.
- i. The concrete ratio should be 1:2:4 for RCC foundation.
- j. Proper sketches of Pole, base plate, RCC Foundation and Steel Rebars cage (Mesh) should be provided and approved from Engineer In-charge.
- k. In order to focus on winter sun availability and Easy cleaning of Solar panel from dust etc with Rain water, Solar Panels should be installed at 180° Azimuth Angle and the Tilt angle (slope) of PV Module should be between 45° ±5° (Only for Solar Street Lights).

### **36. LED SOLAR ROAD/STREET LIGHT FIXTURE:**

1. LED Efficacy must be greater than or equal to 130 Lumens/Watt.
2. The fixture must be IP-66 Rated or above.
3. The Color temperature of the LED should be Pure white in the range of 5000-6000 K.
4. The LED Light distribution must be IESNA Type-II
5. The LED must be suitable for working Temperature from -40 ~ + 60°C with relative humidity of 15% ~ 90%
6. The Color rendering Index (CRI) must be equal or greater than 70.
7. The LED Light Fixture must be LM79 and LM80 Tested.
8. LEDs/Light fixtures should not be Chip-on-board (COB) single chip type due to their poor heat dissipation.
9. LEDs/Light fixtures shall be modular type with proper heat sinks.
10. The output from the LEDs/Light fixtures should be constant throughout the duty cycle
11. LED Life should be greater or equal to than 50,000 Hours.
12. The LED Light Fixture must have the following certification:
  - ISO 9001
  - ISO 14001
  - CE (EMC and LVD) Certified or equivalent.
  - International standard Certifications

**Note: Product Brochure, Catalog and certificates must be attached with the Technical Bid**

Deputy Secretary (Tech.)  
Public Health Engg. Department  
Khyber Pakhtunkhwa

Page 19 of 24

DIRECTOR  
Agril: Engineering  
KPK Tarnab, Peshawar

Jai-Jar 16/01/2019

CC

Familus

16/01/2019

PDA

SENI

SE(H&E)

Handwritten signature and stamp in the top right corner.

**37. SOLAR CHARGE CONTROLLER (FOR STREET / ROAD LIGHTS):**

- a. The charge controller must be suitable for the required battery voltage, auto voltage recognition feature and capable of charging OPzV & Lithium Ferrous Phosphate (LiFePO4) Batteries
- b. The charge controller must be IP-67 rated or above for outdoor installation
- c. The charge controller must be Remote Controlled for parameter setting. The system must have the following feature:
  - Remote Parameter Setting and Monitoring
  - Remote control of the Lights (on/off, timer setting etc)
- d. The charge controller must have MPPT Technology
- e. The charge controller must have at-least three stage Flexible dimming function (0-100%).
- f. The Maximum power point tracking (MPPT) efficiency should be minimum 97%.
- g. It must have temperature compensation for charging batteries in higher temperatures.
- h. Charge controller must have the following protections:
  - PV Short circuit
  - PV reverse polarity
  - PV over voltage
  - PV over current
  - Battery over charging
  - Battery over discharging
  - Battery reverse polarity protection
  - Load short circuit
  - Load overload protections
- i. It must have proper heat sink to dissipate excessive heat
- j. The charge controller must have protection for reverse flow of current through the PV modules
- k. Controller should have active port for GSM based communication for Remote Monitoring.
- l. Mid Night based timing controller will be preferred.
- m. The Solar Charge controller must have the following certification:
  - ISO 9001
  - CE Certified

**Note: Product Brochure, Catalog and certificates must be attached with the Technical Bid**

**38. Battery and Controller Box:**

- a. The battery box should be made of Hot Dipped Galvanized Sheet of average 80 Microns.
- b. The battery box must have vented compartment having inverted louvers.
- c. For Pole Mounted batteries Battery boxes must be made of minimum 16 SWG sheet and must have proper locking arrangement for protection against theft.
- d. For underground battery installation, the battery box should be made of minimum 16 SWG sheet and should be properly sealed to ensure protection against water. Proper cable glands and packing material should be used to ensure water proofing of the box.
- e. The battery and Controller Box should be at least IP65 ingress protection.

**39. Electric Cable:**

The specifications of Electric cables are as under:

- a. Flexible copper cable of proper size along with MC-4 connectors (TUV Approved) from solar panel to charge controller and charge controller to battery as well as to light fixtures.
- b. The cables should be made of minimum 99.9% Pure copper cable

Secretary (Tech:)  
Engg. Department

DIRECTOR  
Agri: Engineering  
PK Tamab, Peshawar

16/01/2019

Page 20 of 24

SECHA

XEN

ERP

PDA

16/01/2019



**ANNEXURE-1 (STRUCTURE DRAWING)**

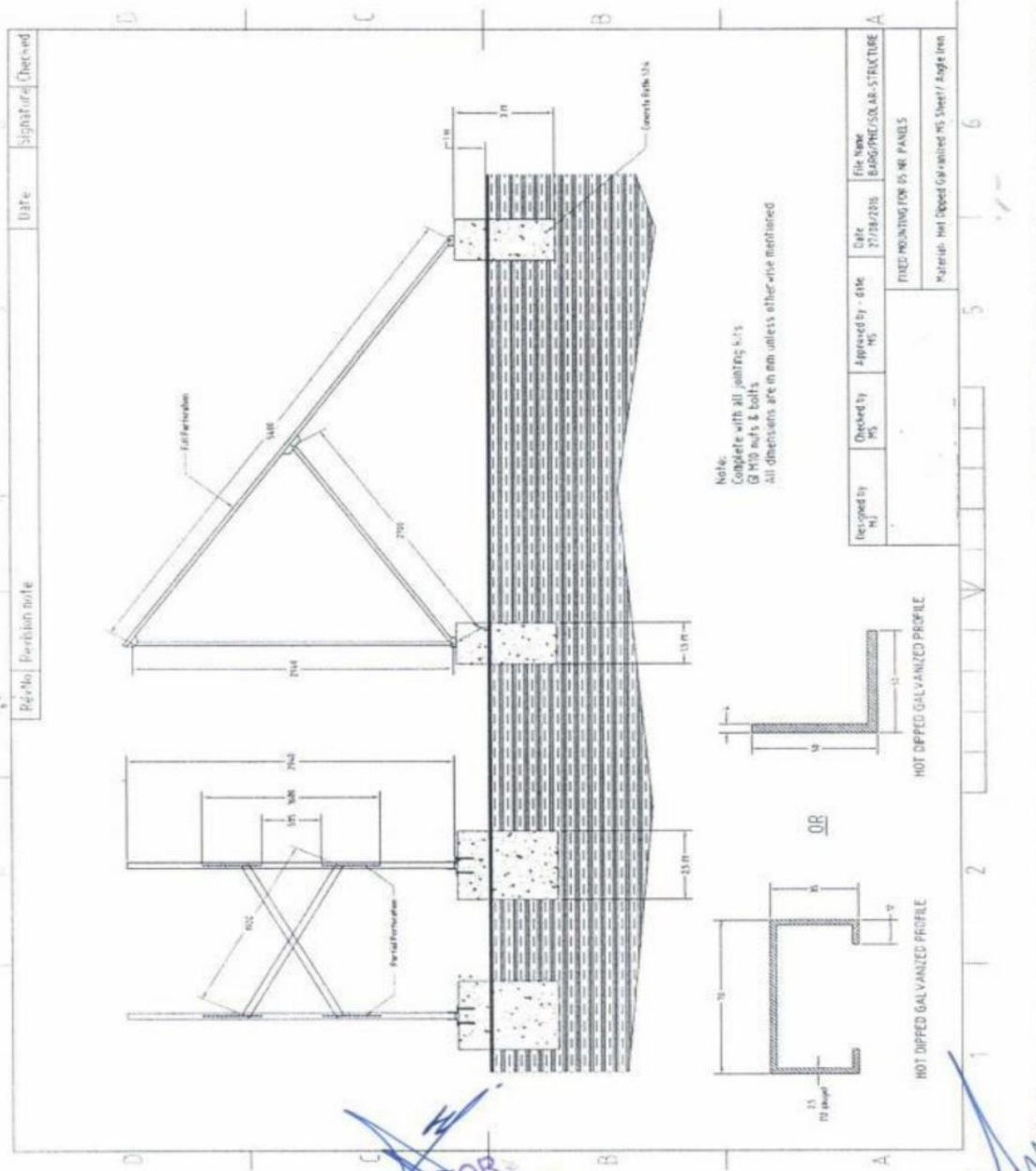

*[Signature]*  
11/10/2019  
Deputy Secretary (Tech.)  
Public Health Engg: Department  
Khyber Pakhtunkhwa

**DIRECTOR**  
Agril: Engineering  
KPK Tamab, Peshawar

*hi-gen.* (16/10/2019)

*CC*

*[Signature]*  
16/10/2019

*[Signature]*  
16/10/2019

*[Signature]*  
PDA

*[Signature]*  
Executive Engineer  
Page 21 of 24  
*Mshad*  
SE(H&E)

*[Signature]*  
XEN.  
*[Signature]*  
ECP

**ANNEXURE-2 (EARTHING / GROUNDING DRAWING)**

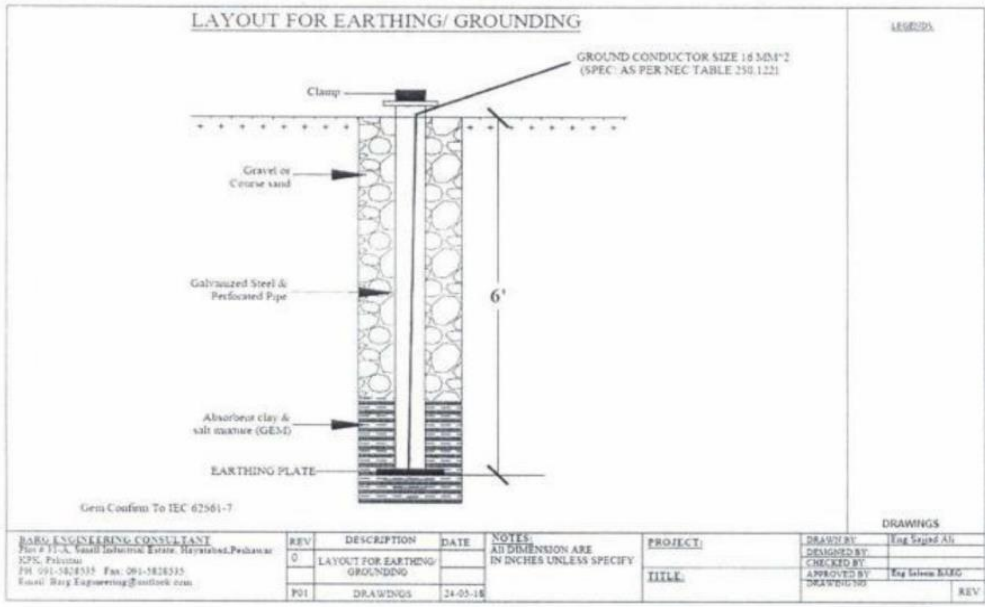

**ANNEXURE-3 TOPSET LAYOUT:**

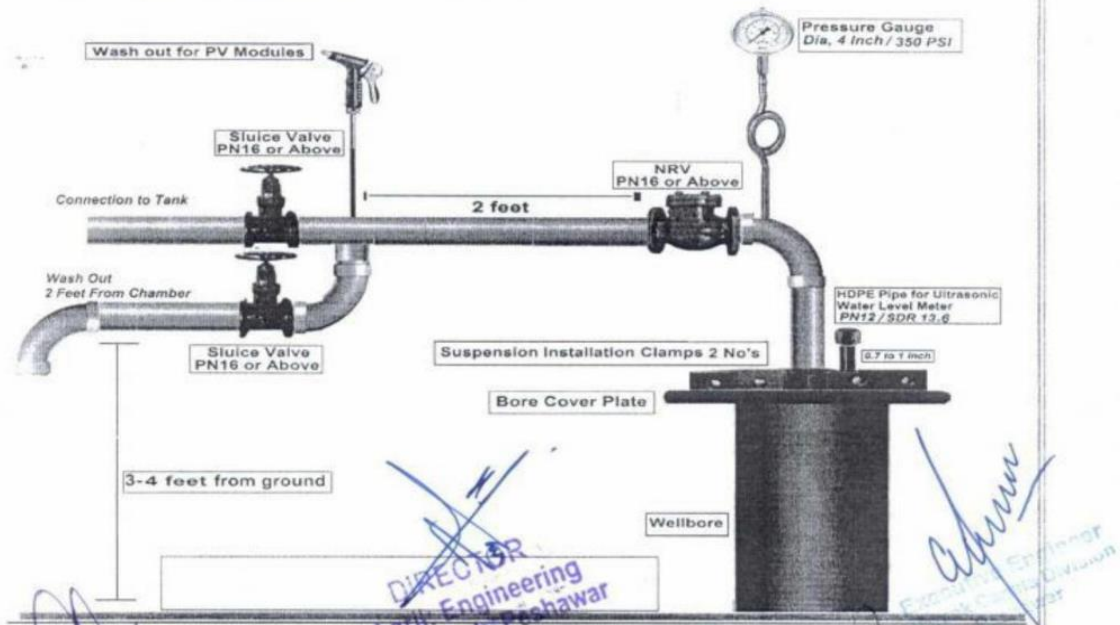

Deputy Secretary (Technical)  
Public Health Engg. Deptt.  
Khyber Pakhtunkhwa

Handwritten signature and date: 16/01/2019

Handwritten signature: PDA

Handwritten initials: C.C.

Handwritten signature and date: 16/01/2019

Handwritten initials: MD / DE / H

Handwritten signature: P. Suresh

Handwritten initials: KEN

Handwritten signature: MSW / SE (HR)



**ANNEXURE-4 (SYSTEM SINGLE LINE DIAGRAM-PUMPING)**

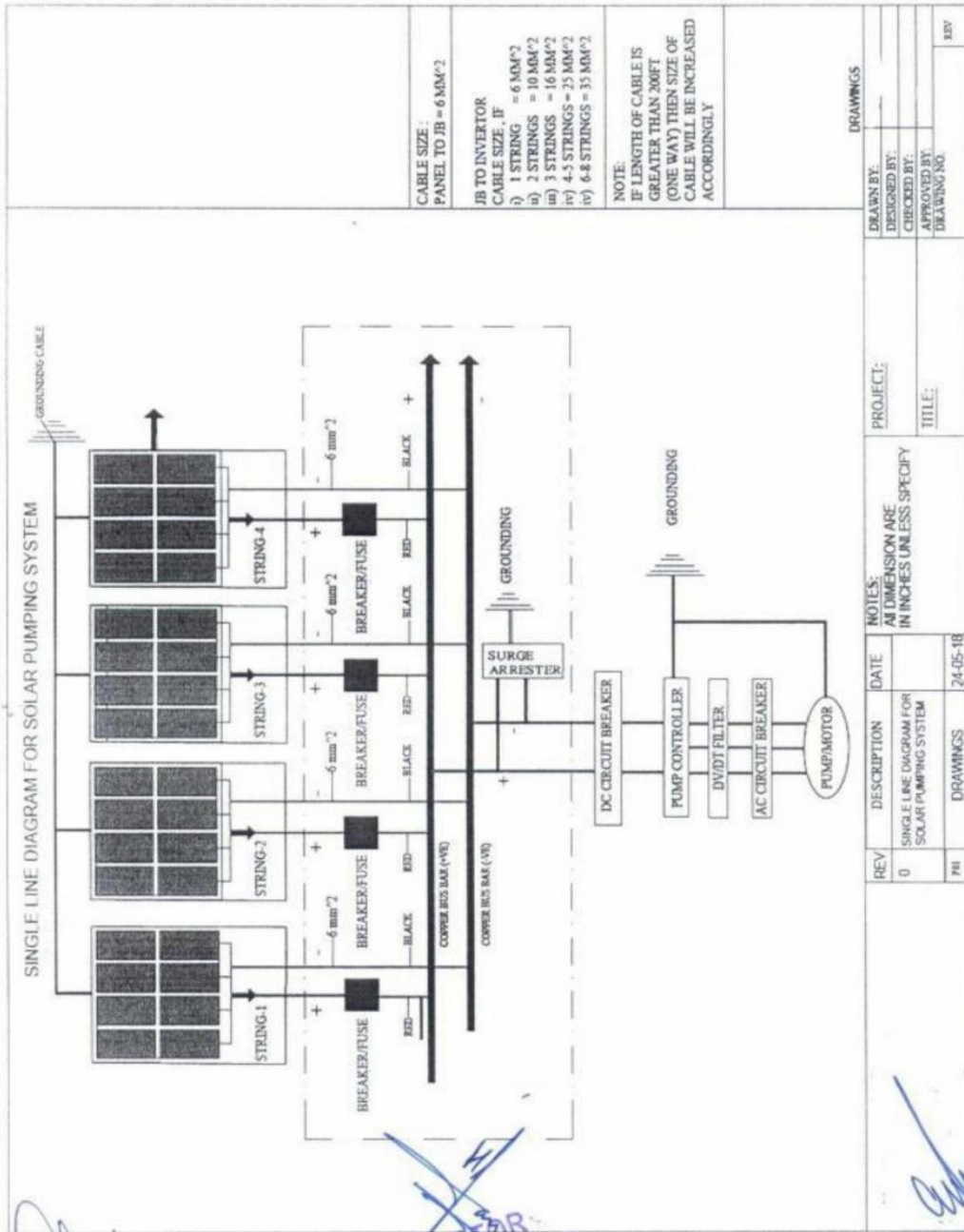

CABLE SIZE :  
 PANEL TO JB = 6 MM<sup>2</sup>  
 JB TO INVERTOR  
 CABLE SIZE , IF  
 i) 1 STRING = 6 MM<sup>2</sup>  
 ii) 2 STRINGS = 10 MM<sup>2</sup>  
 iii) 3 STRINGS = 16 MM<sup>2</sup>  
 iv) 4-5 STRINGS = 25 MM<sup>2</sup>  
 v) 6-8 STRINGS = 35 MM<sup>2</sup>

NOTE:  
 IF LENGTH OF CABLE IS  
 GREATER THAN 200FT  
 (ONE WAY) THEN SIZE OF  
 CABLE WILL BE INCREASED  
 ACCORDINGLY

DRAWINGS  
 DRAWN BY:  
 DESIGNED BY:  
 CHECKED BY:  
 APPROVED BY:  
 DRAWING NO.  
 REV

PROJECT:  
 TITLE:  
 NOTES:  
 ALL DIMENSION ARE  
 IN INCHES UNLESS SPECIFY

REV	DESCRIPTION	DATE
0	SINGLE LINE DIAGRAM FOR SOLAR PUMPING SYSTEM	

PHI DRAWINGS 24-05-18

Deputy Secretary (Tech.)  
 Public Health Engg. Department  
 F-7/1, F-7/2  
 F-7/3  
 F-7/4  
 F-7/5  
 F-7/6  
 F-7/7  
 F-7/8  
 F-7/9  
 F-7/10  
 F-7/11  
 F-7/12  
 F-7/13  
 F-7/14  
 F-7/15  
 F-7/16  
 F-7/17  
 F-7/18  
 F-7/19  
 F-7/20  
 F-7/21  
 F-7/22  
 F-7/23  
 F-7/24  
 F-7/25  
 F-7/26  
 F-7/27  
 F-7/28  
 F-7/29  
 F-7/30  
 F-7/31  
 F-7/32  
 F-7/33  
 F-7/34  
 F-7/35  
 F-7/36  
 F-7/37  
 F-7/38  
 F-7/39  
 F-7/40  
 F-7/41  
 F-7/42  
 F-7/43  
 F-7/44  
 F-7/45  
 F-7/46  
 F-7/47  
 F-7/48  
 F-7/49  
 F-7/50

**DIRECTOR**  
 Agril. Engineering  
 K.P.K. Tamab, Peshawar

16/01/2019

PDA

Handwritten signature

16/01/2019

Handwritten signature and initials

Handwritten signature

Mshah  
 SE (HE)

**ANNEXURE-5  
(JUNCTION/COMBINER BOX SCHEMATICS DIAGRAM)**

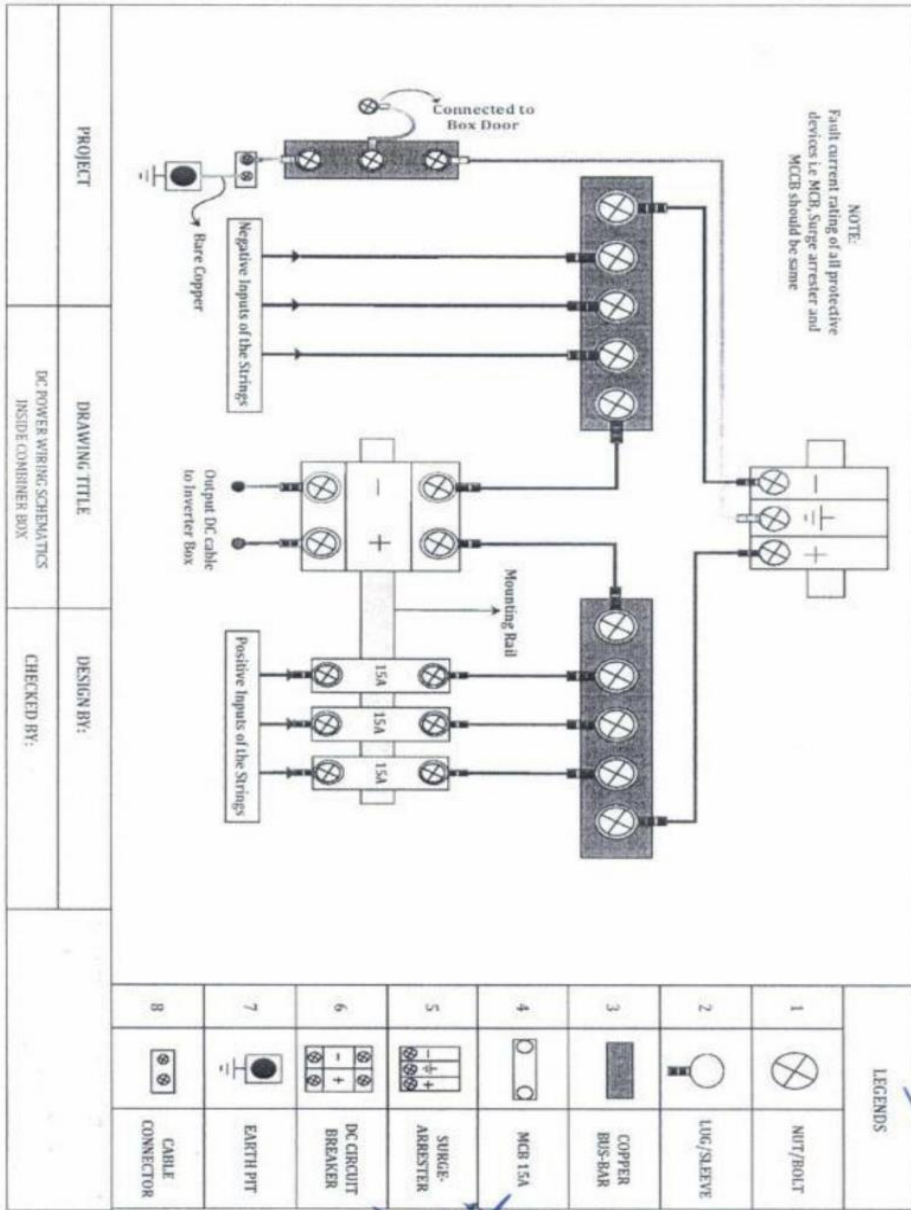

011

PROJECT	DRAWING TITLE	DESIGN BY:
	DC POWER WIRING SCHEMATICS INSIDE COMBINER BOX	CHECKED BY:

LEGENDS	
1	NUT/BOLT
2	LUG/SLEEVE
3	COPPER BUS-BAR
4	MCB 15A
5	SURGE-ARRESTER
6	DC CIRCUIT BREAKER
7	EARTH PIT
8	CABLE CONNECTOR

15A

Deputy Secretary (Tech.)  
Public Health Engg: Department  
Khyber Pakhtunkhwa

**DIRECTOR**  
Agril. Engineering  
KPK Tarnab, Peshawar

16/01/2019

2007

2007

16/01/2019

16/01/2019

16/01/2019

16/01/2019

*Signature*

*Signature*  
SEC(HQ)

Executive Engineer  
Khyber Pakhtunkhwa